



MASON INDUSTRIES, Inc.

Manufacturers of Vibration Control Products
NY Mailing Address: PO Box 410, Smithtown, NY 11787
350 Rabro Drive 2101 W. Crescent Ave., Suite D
Hauppauge, NY 11788 Anaheim, CA 92801
631/348-0282 714/535-2727
FAX 631/348-0279 FAX 714/535-5738
Info@Mason-Ind.com Info@MasonAnaheim.com

TYPE 30 AND 30N HANGER INSTALLATION INSTRUCTIONS

DATE 11/28/00

DRAWING NO. A-26960

INSTALLATION INSTRUCTIONS

1. Install equipment in operating position - temporarily supported with rigging as required.
2. Install the color coded hangers at positions shown on Mount Location Diagram.
3. Attach hanger boxes to upper and lower rods and assemble as shown in illustration. Note minimum rod lengths, maximum rod diameters and hanger box heights for proper fit.
4. Adjustment is made by turning top nuts on lower rods which pass through the springs. Take three clockwise turns on each hanger nut to compress springs uniformly and avoid overloading individual hangers. Repeat this procedure until rigging supports can be removed.
5. Level equipment by taking additional turns at any low point.

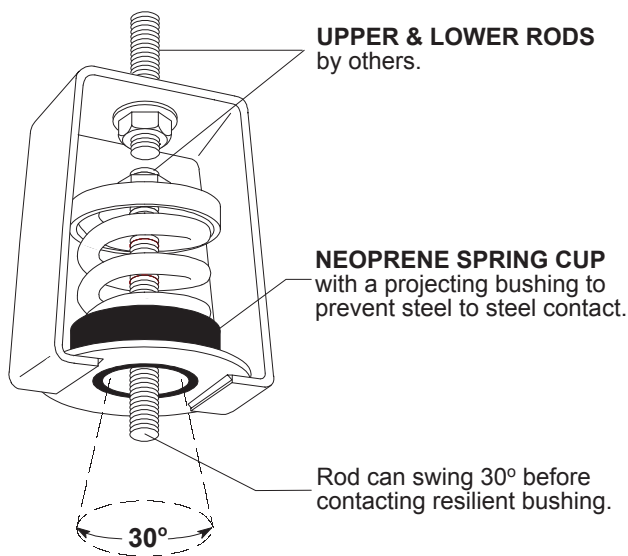

TYPE 30

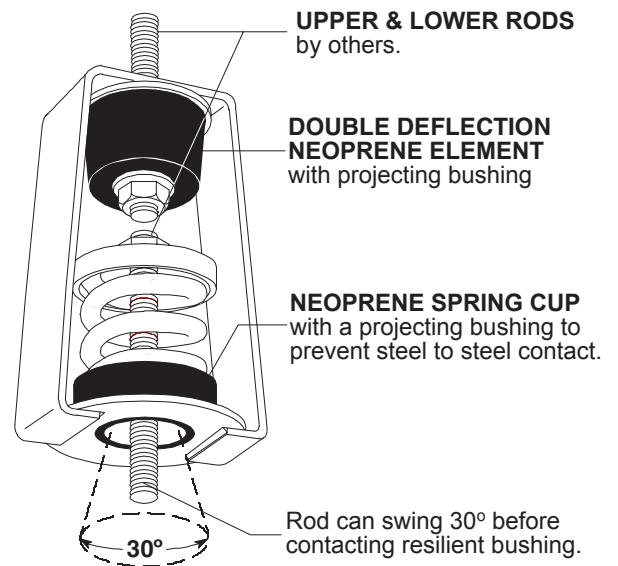

TYPE 30N

DWN :	CHKD :	DATE :
-------	--------	--------