

MERCER FLEXMORE EXPANSION JOINTS

Series WA450 & 450

PERFORMANCE FEATURES

- Working pressures up to 250 psi in all sizes
- Greater movements per arch
- Manufactured in one to six arches
- Minimum 3 to 1 safety factor to burst pressure
- Wide arch contour provides controlled extension under pressure
- Lower spring rates

CONSTRUCTION FEATURES

- Choice of eight cover elastomers
- Sizes up to 36" diameter
- Optional Coating of Hypalon® paint
- Standard 150 lb ASA Drilling, Ductile Iron Back-up Rings
- Filled or Unfilled Arches
- Lightweight

SERIES 450

Mercer Flexmore Series 450 is the most economical, full-pressure elastometric expansion joint available. Tough fabric and tirecord plies are bonded between the tube and cover in a steel mold and then cured in a thermostatically controlled steam chamber. The product is uniform in both appearance and performance. A wide, low profile arch provides exceptional flexibility and virtually eliminates the need for filled arches in all but the most severe sludge and slurry applications. External integral flange reinforcing rings control both radial and arch swell. A variety of cover and tube elastomers are available, offering superior chemical, aging and temperature resistance from -30° to +250°F (Max 250°F for intermittent service) operating temperatures.

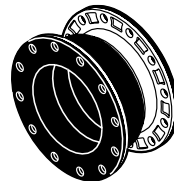

1 ARCH
Style WA451 & 451

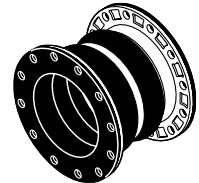

2 ARCH
Style 452

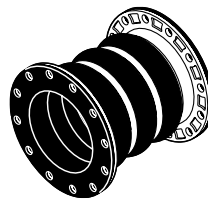

3 ARCH
Style 453

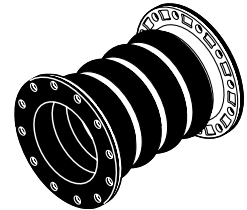

4 ARCH
Style 454

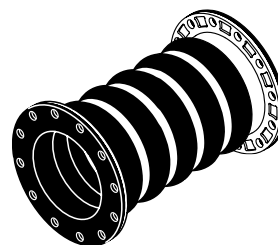

5 ARCH
Style 455

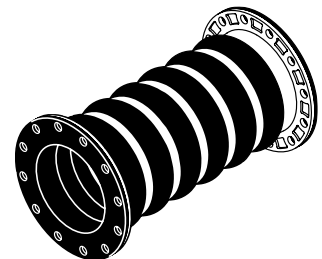

6 ARCH
Style 456

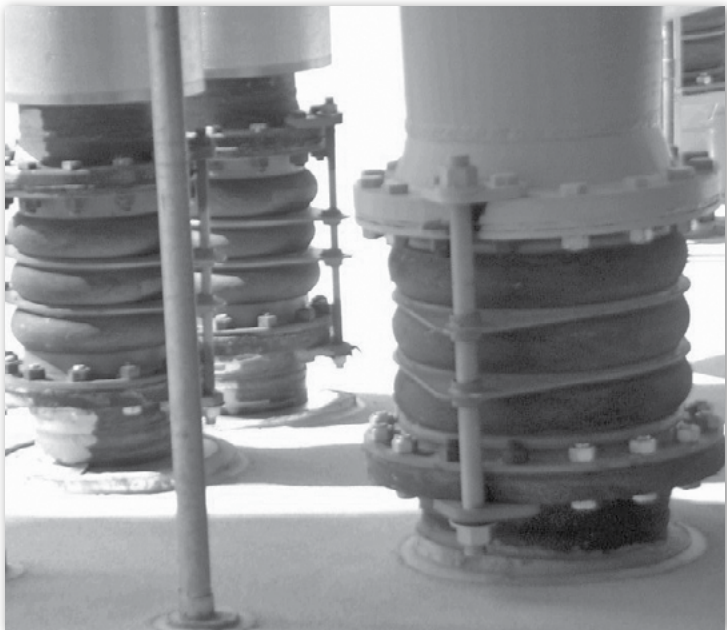

12" diameter 3 arch 453 expansion joints in cooling tower, high movement seismic application in California

Series 450
1 ARCH

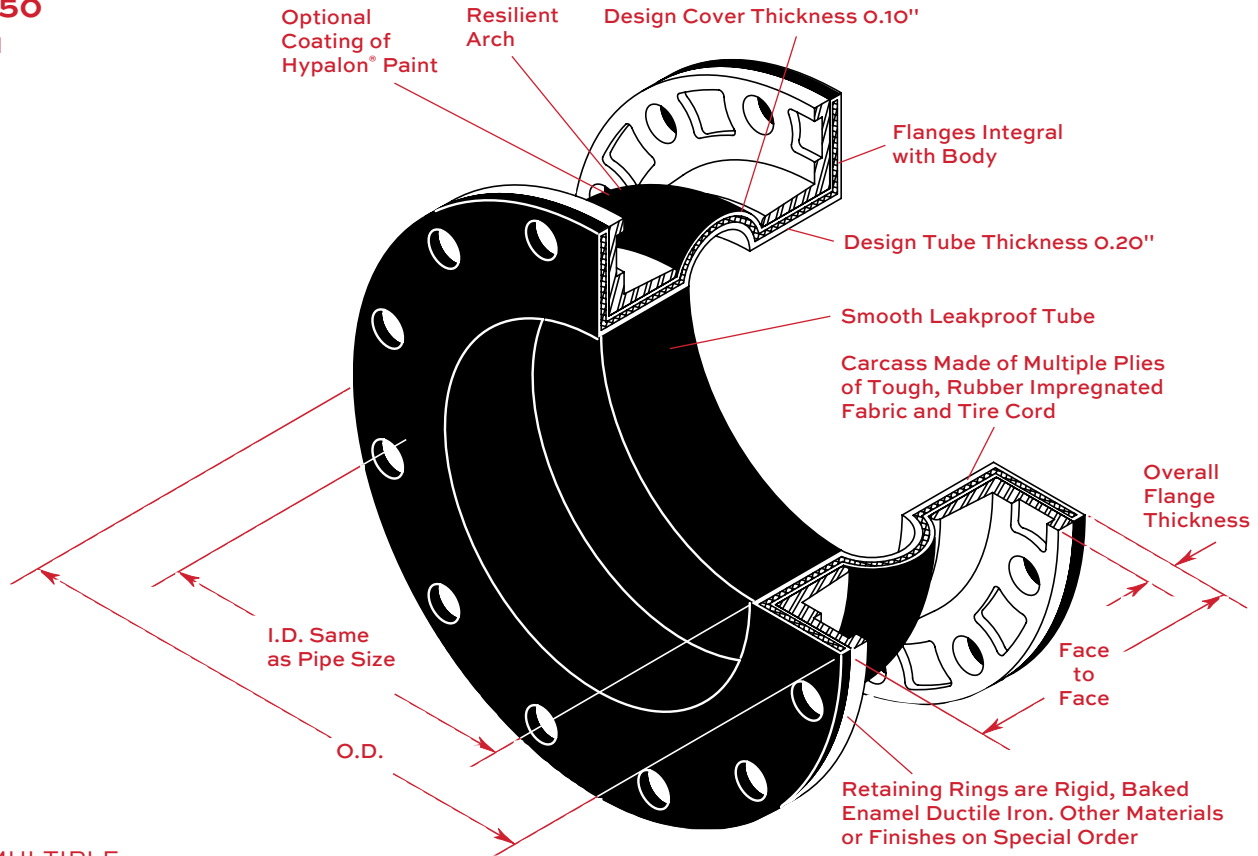

TYPICAL MULTIPLE ARCH CONSTRUCTION

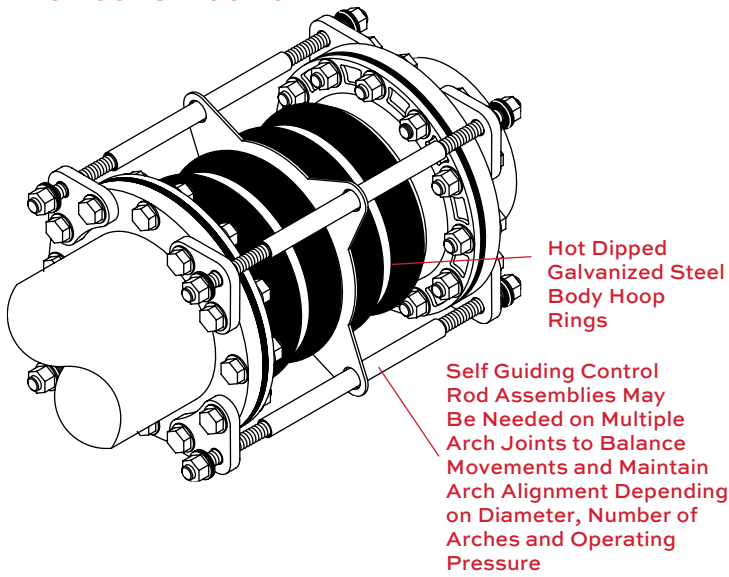

OPTIONAL FILLED ARCH CONSTRUCTION

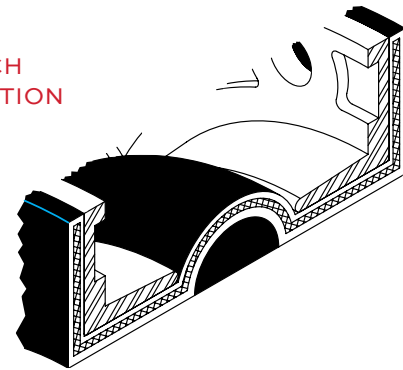

SERIES 450
MATERIAL AVAILABILITY
& OPERATING TEMPERATURES

Series 450	Standard Materials		Max. Oper. Temp.
	Tube	Cover	
B	Butyl	Butyl	225°F*
E	EPDM	EPDM	225°F*
H	Hypalon®	Hypalon®	225°F
HN	Hypalon®	Neoprene	225°F
N	Neoprene	Neoprene	225°F
NH	Neoprene	Hypalon®	225°F
Ni	Nitrile	Nitrile	210°F
NiN	Nitrile	Neoprene	210°F
NR	Neoprene	Natural	180°F
R	Natural	Natural	180°F
RN	Natural	Neoprene	180°F
V	Viton®	Viton®	225°F

SERIES 450 DRILLING DIMENSIONS ASA CLASS 150 LB

Pipe Size (in)	Flange Outside Dia. (in)	Overall Flange Thickness (in)	Bolt Circle Dia. (in)	Number of Holes	Bolt Hole Dia. (in)
1 1/2	5	3/4	37/8	4	5/8
2	6	13/16	43/4	4	3/4
2 1/2	7	13/16	51/2	4	3/4
3	7 1/2	13/16	6	4	3/4
4	9	7/8	7 1/2	8	3/4
5	10	7/8	8 1/2	8	7/8
6	11	7/8	9 1/2	8	7/8
8	13 1/2	7/8	11 3/4	8	7/8
10	16	7/8	14 1/4	12	7/8
12	19	7/8	17	12	7/8
14	21	1	18 3/4	12	11/8
16	23 1/2	1	21 1/4	16	11/8
18	25	1	22 3/4	16	1 1/4
20	27 1/2	1	25	20	1 1/4
24	32	1	29 1/2	20	1 3/8
30	38 3/4	1	36	28	1 3/8
36	46	1 1/4	42 3/4	32	1 5/8

*Max 250°F for intermittent service; see Note 2 under 'CAUTION' on page 9-89.

1 ARCH
Style WA451 & 451

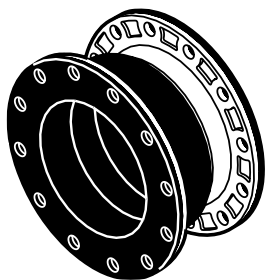

VACUUM RATINGS

Size (in)	Vacuum Ratings (Hg)
11/2 - 12	29"
14 - 36	15"

TEMPERATURE & PRESSURE RATINGS

Standard Materials	Max. Pressure (psig @ °F)		Max. Temp. (psig @ °F)	
	(psig)	(deg)	(psig)	(deg)
Natural Rubber	250	≤150°F	225	180°F
Chlorobutyl	250	≤150°F	180	225°F
Neoprene	250	≤150°F	180	225°F
Hypalon®	250	≤150°F	180	225°F
Nitrile (Buna)	250	≤150°F	200	210°F
EPDM	250	≤150°F	180	225°F
Viton®	250	≤150°F	180	225°F

STYLE WA451 ALLOWABLE MOVEMENTS

Pipe Size	Face to Face (in)	Axial Compression (in)	Axial Extension (in)	Lateral Deflection (in)	Degrees Angular (deg)	Degrees Torsional (deg)
1 1/2	6	2	1 1/8	1 1/8	55	8
2	6	2	1 1/8	1 1/8	43	7
2 1/2	6	2	1 1/8	1 1/8	35	7
3	6	2	1 1/8	1 1/8	29	6
4	6	2	1 1/8	1 1/8	26	6
5	6	2	1 1/8	1 1/8	21	5
6	6	2	1 1/8	1 1/8	18	5
8	6	2	1 1/8	1 1/8	13	4
10	8	2 1/4	1 1/4	1 1/4	20	4
12	8	2 1/4	1 1/4	1 1/4	16	4

STYLE 451 ALLOWABLE MOVEMENTS

Pipe Size	Face to Face (in)	Axial Compression (in)	Axial Extension (in)	Lateral Deflection (in)	Degrees Angular (degrees)	Degrees Torsional (degrees)
14	8	2 1/8	1	1 1/4	10	3
16	8	2 1/8	1	1 1/4	8	3
18	8	2 1/8	1	1 1/4	7	3
20	8	2 1/8	1	1 1/4	7	3
24	10	2 5/8	1 1/4	1 1/2	7	3
30	10	2 5/8	1 1/4	1 1/2	5	3
36	10	2 5/8	1 1/4	1 1/2	4	2

2 ARCH
Style 452



VACUUM RATINGS

Size (in)	Vacuum Ratings (Hg)
11/2 - 12	15"
14 - 36	10"

TEMPERATURE & PRESSURE RATINGS

Standard Materials	Max. Pressure (psig @ °F)		Max. Temp. (psig @ °F)	
	(psig)	(deg)	(psig)	(deg)
Natural Rubber	250	≤150°F	225	180°F
Chlorobutyl	250	≤150°F	180	225°F
Neoprene	250	≤150°F	180	225°F
Hypalon®	250	≤150°F	180	225°F
Nitrile (Buna)	250	≤150°F	200	210°F
EPDM	250	≤150°F	180	225°F
Viton®	250	≤150°F	180	225°F

STYLE 452 ALLOWABLE MOVEMENTS

Pipe Size	Face to Face (in)	Axial Compression (in)	Axial Extension (in)	Lateral Deflection (in)	Degrees Angular (deg)	Degrees Torsional (deg)
1 1/2	10	3 1/2	1 3/4	2	73	14
2	10	3 1/2	1 3/4	2	66	14
2 1/2	10	3 1/2	1 3/4	2	59	12
3	10	3 1/2	1 3/4	2	54	11
4	10	3 1/2	1 3/4	2	45	9
5	10	3 1/2	1 3/4	2	38	9
6	10	3 1/2	1 3/4	2	33	8
8	10	3 1/2	1 3/4	2	25	6
10	12	3 1/2	1 3/4	2	21	6
12	12	3 1/2	1 3/4	2	17	5
14	12	4 3/8	2 1/8	2 1/2	19	5
16	12	4 3/8	2 1/8	2 1/2	16	5
18	12	4 3/8	2 1/8	2 1/2	15	5
20	12	4 3/8	2 1/8	2 1/2	13	5
24	15	5 1/4	2 1/2	3	13	4
30	15	5 1/4	2 1/2	3	11	4
36	15	5 1/4	2 1/2	3	9	3

NOTE: Drilling Dimensions for all sizes are on page 9-85.



3 ARCH
Style 453

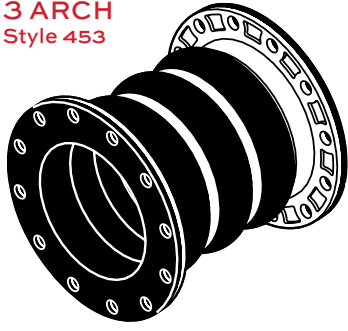

VACUUM RATINGS

Size (in)	Vacuum Ratings (Hg)
1 1/2 - 12	15"
14 - 36	10"

TEMPERATURE & PRESSURE RATINGS

Standard Materials	Max. Pressure (psig @ °F)		Max. Temp. (psig @ °F)	
	(psig)	(deg)	(psig)	(deg)
Natural Rubber	250	≤150°F	225	180°F
Chlorobutyl	250	≤150°F	180	225°F
Neoprene	250	≤150°F	180	225°F
Hypalon®	250	≤150°F	180	225°F
Nitrile (Buna)	250	≤150°F	200	210°F
EPDM	250	≤150°F	180	225°F
Viton®	250	≤150°F	180	225°F

STYLE 453 ALLOWABLE MOVEMENTS

Pipe Size	Face to Face (in)	Axial Compression (in)	Axial Extension (in)	Lateral Deflection (in)	Degrees Angular (deg)	Degrees Torsional (deg)
1 1/2	14	5 1/4	2 5/8	3	81	21
2	14	5 1/4	2 5/8	3	76	20
2 1/2	14	5 1/4	2 5/8	3	70	18
3	14	5 1/4	2 5/8	3	66	16
4	14	5 1/4	2 5/8	3	57	13
5	14	5 1/4	2 5/8	3	50	13
6	14	5 1/4	2 5/8	3	45	12
8	14	5 1/4	2 5/8	3	36	10
10	16	5 1/4	2 5/8	3	30	9
12	16	5 1/4	2 5/8	3	25	8
14	16	6 1/2	3 1/4	3 5/8	27	8
16	16	6 1/2	3 1/4	3 5/8	24	7
18	16	6 1/2	3 1/4	3 5/8	22	7
20	16	6 1/2	3 1/4	3 5/8	20	7
24	20	7 7/8	3 7/8	4 1/2	20	6
30	20	7 7/8	3 7/8	4 1/2	16	6
36	20	7 7/8	3 7/8	4 1/2	13	5

4 ARCH
Style 454

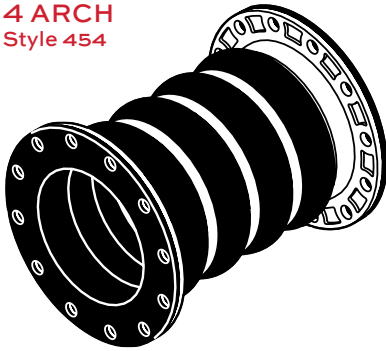

VACUUM RATINGS

Size (in)	Vacuum Ratings (Hg)
1 1/2 - 12	15"
14 - 36	10"

TEMPERATURE & PRESSURE RATINGS

Standard Materials	Max. Pressure (psig @ °F)		Max. Temp. (psig @ °F)	
	(psig)	(deg)	(psig)	(deg)
Natural Rubber	250	≤150°F	225	180°F
Chlorobutyl	250	≤150°F	180	225°F
Neoprene	250	≤150°F	180	225°F
Hypalon®	250	≤150°F	180	225°F
Nitrile (Buna)	250	≤150°F	200	210°F
EPDM	250	≤150°F	180	225°F
Viton®	250	≤150°F	180	225°F

STYLE 454 ALLOWABLE MOVEMENTS

Pipe Size	Face to Face (in)	Axial Compression (in)	Axial Extension (in)	Lateral Deflection (in)	Degrees Angular (deg)	Degrees Torsional (deg)
1 1/2	18	7	3 1/2	4	86	26
2	18	7	3 1/2	4	81	26
2 1/2	18	7	3 1/2	4	77	22
3	18	7	3 1/2	4	73	20
4	18	7	3 1/2	4	66	16
5	18	7	3 1/2	4	59	17
6	18	7	3 1/2	4	54	15
8	18	7	3 1/2	4	45	12
10	20	7	3 1/2	4	38	11
12	20	7	3 1/2	4	33	9
14	20	8 3/4	4 1/4	5	35	10
16	20	8 3/4	4 1/4	5	31	9
18	20	8 3/4	4 1/4	5	28	9
20	20	8 3/4	4 1/4	5	25	9
24	26	10 1/2	5	6	25	8
30	26	10 1/2	5	6	21	7
36	26	10 1/2	5	6	17	6

NOTE: Drilling Dimensions for all sizes are on page 9:85.

5 ARCH
Style 455

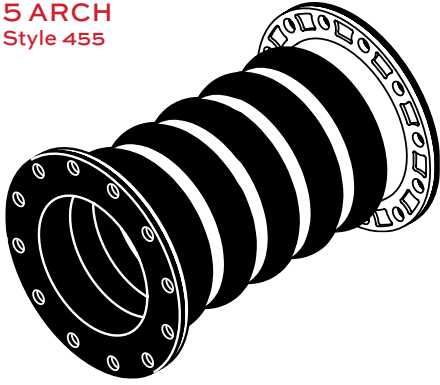

VACUUM RATINGS

Size (in)	Vacuum Ratings (Hg)
11/2 - 12	10"
14 - 36	5"

TEMPERATURE & PRESSURE RATINGS

Standard Materials	Max. Pressure (psig @ °F)		Max. Temp. (psig @ °F)	
	(psig)	(deg)	(psig)	(deg)
Natural Rubber	250	≤150°F	225	180°F
Chlorobutyl	250	≤150°F	180	225°F
Neoprene	250	≤150°F	180	225°F
Hypalon®	250	≤150°F	180	225°F
Nitrile (Buna)	250	≤150°F	200	210°F
EPDM	250	≤150°F	180	225°F
Viton®	250	≤150°F	180	225°F

STYLE 455 ALLOWABLE MOVEMENTS

Pipe Size	Face to Face (in)	Axial Compression (in)	Axial Extension (in)	Lateral Deflection (in)	Degrees Angular (deg)	Degrees Torsional (deg)
11/2	21	83/4	43/8	5	88	33
2	21	83/4	43/8	5	85	32
2 1/2	21	83/4	43/8	5	81	28
3	21	83/4	43/8	5	78	25
4	21	83/4	43/8	5	71	20
5	21	83/4	43/8	5	66	21
6	21	83/4	43/8	5	60	19
8	21	83/4	43/8	5	52	15
10	24	83/4	43/8	5	45	14
12	24	83/4	43/8	5	39	12
14	24	107/8	5	61/8	41	12
16	24	107/8	5	61/8	37	11
18	24	107/8	5	61/8	34	11
20	24	107/8	5	61/8	31	11
24	31	131/8	61/4	73/8	31	9
30	31	131/8	61/4	73/8	25	9
36	31	131/8	61/4	73/8	22	8

6 ARCH
Style 456

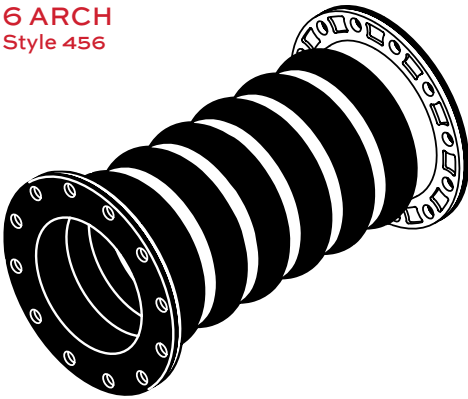

VACUUM RATINGS

Size (in)	Vacuum Ratings (Hg)
11/2 - 12	10"
14 - 36	5"

TEMPERATURE & PRESSURE RATINGS

Standard Materials	Max. Pressure (psig @ °F)		Max. Temp. (psig @ °F)	
	(psig)	(deg)	(psig)	(deg)
Natural Rubber	250	≤150°F	225	180°F
Chlorobutyl	250	≤150°F	180	225°F
Neoprene	250	≤150°F	180	225°F
Hypalon®	250	≤150°F	180	225°F
Nitrile (Buna)	250	≤150°F	200	210°F
EPDM	250	≤150°F	180	225°F
Viton®	250	≤150°F	180	225°F

STYLE 456 ALLOWABLE MOVEMENTS

Pipe Size	Face to Face (in)	Axial Compression (in)	Axial Extension (in)	Lateral Deflection (in)	Degrees Angular (deg)	Degrees Torsional (deg)
11/2	24	101/2	51/8	6	90	41
2	24	101/2	51/8	6	87	40
2 1/2	24	101/2	51/8	6	84	34
3	24	101/2	51/8	6	81	32
4	24	101/2	51/8	6	76	25
5	24	101/2	51/8	6	70	26
6	24	101/2	51/8	6	66	23
8	24	101/2	51/8	6	57	19
10	28	101/2	51/8	6	50	18
12	28	101/2	51/8	6	45	15
14	28	13	63/8	73/8	47	15
16	28	13	63/8	73/8	43	13
18	28	13	63/8	73/8	39	14
20	28	13	63/8	73/8	36	14
24	36	153/4	71/2	83/4	36	12
30	36	153/4	71/2	83/4	30	11
36	36	153/4	71/2	83/4	25	10

See note on page 9-85 on "Self Guiding Control Rods".
NOTE: Drilling Dimensions for all sizes are on page 9-85.

CAUTION

1. Do not install any of the products in this bulletin at pressures or temperatures higher than the published ratings.
2. 450 Butyl, EPDM & Viton® connectors are recommended for intermittent (10 minute maximum exposure per hour) 250°F. service or continuous service at a maximum of 225°F. Use Mercer series 500, 600, HT500 or HT600 as described in bulletin 500-MR7 (pages 9-90 - 9-97) for continuous temperatures of 230°F and higher.
3. Series 450 must be installed against standard 1/16" raised faced or flat faced flanges. Do not install them against recessed flanges such as Victaulic without calling the factory for proper steel filler flanges. If our rubber flanges

do not have full bearing, the expansion joint will be damaged and leak or fail.

4. Initial misalignment should be kept to a minimum of 1/8".
5. Pipe system flanges must be smooth and flat. Screw in brass inserts such as those used in check valves can damage the rubber faces if they project above the cast flange face.
6. Water type check valves must exactly center on the rubber flanges. Valve O.D. and I.D. should be checked for conformance with raised face dimensions
7. Check Chemical Resistance Guide CRG-MR1 (pages 9-59 - 9-68) for service elastomer compatibility.

CONTROL RODS

Expansion Joints installed in piping systems that are anchored on both sides of connectors need no control rods, providing piping movements are within the tabulated allowables.

Expansion joints installed in unanchored piping or connected to isolated equipment must have control rods; those control rods must be properly set so that allowable movements are not exceeded.

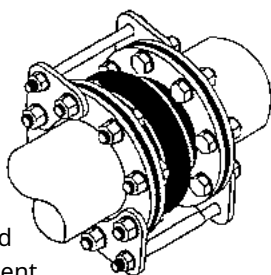

The number of control rods is determined by the maximum working pressure of the pipeline, not the maximum pressure rating of the joint. Use the convenient chart to the right to specify. Control rods are designed for a 3:1 safety factor as is; please use accordingly. For example, if a 24" 452 joint is installed in a pipeline with a maximum pressure of 120 psig, 3 control rods are required. If the maximum pressure of the pipeline is 220 psig, 5 control rods are required.

SERIES 450 CONTROL ROD CALCULATIONS

Pipe Size (in)	Arch Height (in)	Gusset Thickness (in)	Rod Dia. (in)	Joint Thrust Area (sq. in)	Maximum Operation Pressure (psig) for Specified Number of Rods				
					2	3	4	5	6
1 1/2	1	1/4	1/2	10	250	—	—	—	—
2	1	3/8	5/8	13	250	—	—	—	—
2 1/2	1	3/8	5/8	16	250	—	—	—	—
3	1	3/8	5/8	20	250	—	—	—	—
4	1	3/8	5/8	28	250	—	—	—	—
5	1	3/8	5/8	38	250	—	—	—	—
6	1	1/2	5/8	50	250	—	—	—	—
8	1	1/2	3/4	79	250	—	—	—	—
10	1	3/4	7/8	113	250	—	—	—	—
12	1	3/4	1	154	240	250	—	—	—
14	1 1/4	3/4	1	214	174	250	—	—	—
16	1 1/4	3/4	1 1/8	269	175	250	—	—	—
18	1 1/4	3/4	1 1/8	330	143	211	250	—	—
20	1 1/4	3/4	1 1/8	398	117	175	234	250	—
24	1 1/2	1	1 1/4	573	100	150	201	250	—
30	1 1/2	1 1/4	1 1/2	855	97	145	193	242	250
36	1 1/2	1 1/2	1 3/4	1195	94	141	188	236	250