

MERCER INVINCIBLE TEFLON[®] LINED EXPANSION JOINTS

Series
**700 &
HT700**

PERFORMANCE FEATURES

- Working pressures up to 165 psi at temperatures up to 400°F in standard models, higher pressure ratings available
- Minimum 4 to 1 safety factor, rated to burst pressure
- Teflon[®] liner is etched and permanently bonded to expansion joint body and flange faces
- Components are pressure cured resulting in structurally sound, long service life
- Optional exterior coat of Hypalon[®] paint provides additional protection against ozone weathering and chemical exposure
- Hand-built to your exact specifications

CONSTRUCTION FEATURES

- Choice of eight cover elastomers
- Sizes up to 96" diameter
- Baked Enamel, Ductile Iron, Carbon or Stainless Steel Split Backup Rings
- Corrosion resistant, chemically inert and non-aging Teflon[®] liner
- Control rods to restrict excessive elongation or compression
- High temperature resistant fabric reinforcement for operating temperatures up to 400°F

SERIES 700

Mercer Invincible Series 700 Teflon[®] lined expansion joints combine the advantages of Teflon[®]:

- Anti-stick properties
- Superior Strength
- Excellent chemical resistance
- Non-aging

with the advantages of Mercer's elastomeric expansion joints:

- Isolate mechanical vibration
- Allow four-way movements (Axial, lateral, torsional, angular), eliminating problems of pipes buckling or pulling apart
- Long life expectancy
- Absorb pressure surges
- Eliminate electrolysis
- Small space requirements

The result is an expansion joint that offers unmatched protection against highly corrosive fluids and extreme temperatures.

The Series 700 features either a TFE* or FED** seamless liner that extends through the body of the expansion joint to the outer edge of raised flange faces. The liner is fused to the body when the joint is cured. This type of construction provides ultimate



protection against chemicals seeping or leaking. An optional coat of Hypalon[®] paint is recommended to protect the exterior against weather, ozone and chemicals.

The Invincible Series 700 is specifically designed for the severe service conditions found in:

- Power generating plants
- Wastewater treatment and pollution control systems
- Chemical plants
- Petrochemical and process piping systems
- Pulp and paper mills
- Where expansion joints must be able to withstand high temperatures and corrosive materials on a daily basis

The performance of the Invincible Series 700 in these applications is unequalled by plastic, metallic or other elastomeric expansion joints.

SERIES HT700

Invincible Series HT700 combines all the construction and performance advantages of the 700 with high temperature resistance. Reinforced with high temperature resistant fabric, and with the cover of either EPDM or Viton[®], the HT700 can provide full pressure service at operating temperatures up to 350°F and 400°F respectively.

BACKUP RINGS

Standard expansion joints are furnished with ASA-150 backup rings. Series ASA-300, DIN, PN, JIS and British Standards are also available, but sometimes at higher cost. Check factory for pricing.

*Teflon[®] is a trademark of E.I. DuPont Nemours & Co.
**FED - Fluorinated Ethylene Propylene Copolymer

Series 700 & HT700

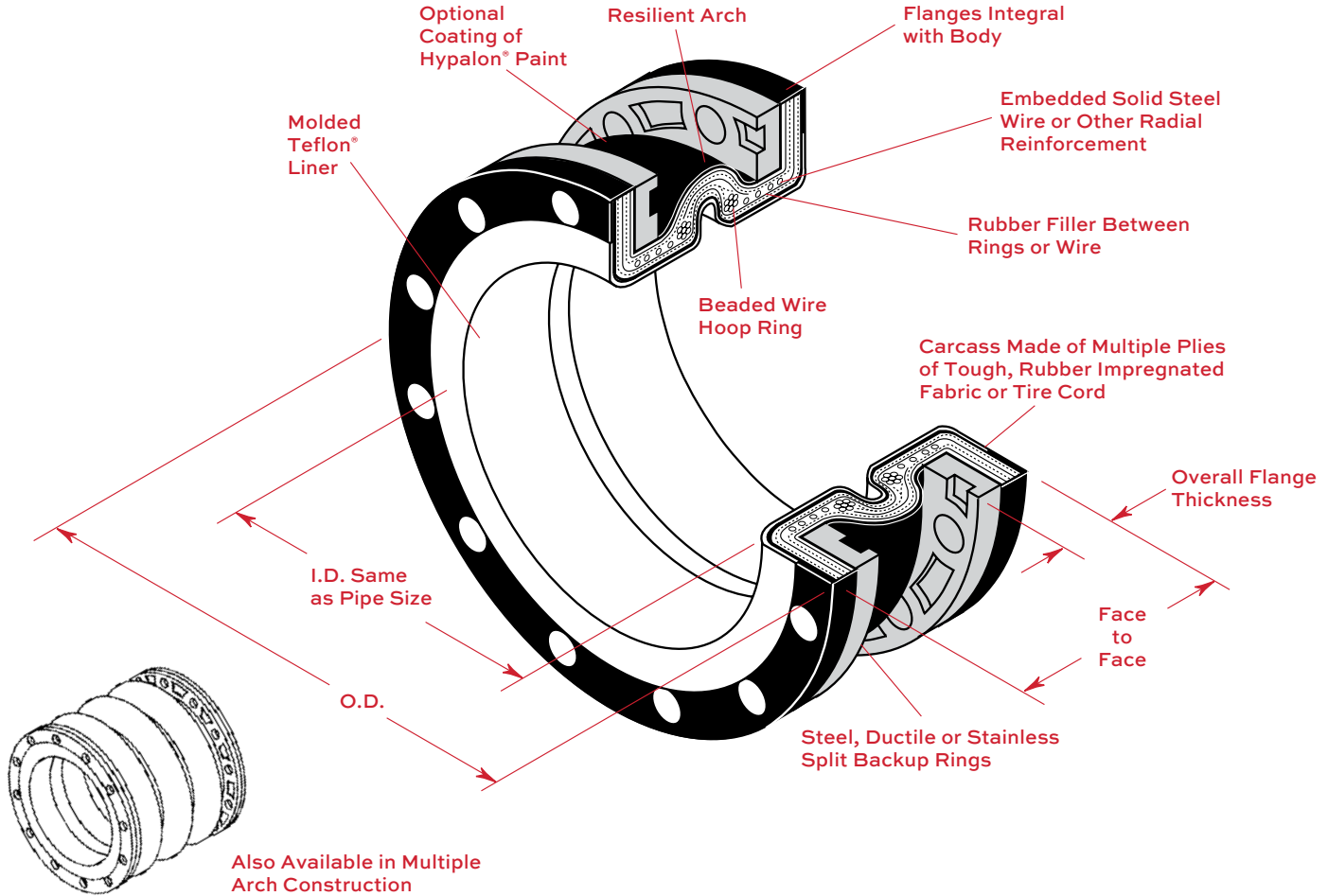

UNANCHORED PIPING APPLICATIONS

Series 700 & HT700 expansion joints used as noise & vibration dampeners installed in unanchored piping will overextend in response to system pressure & must be installed with control rod assemblies.

Adjust the spring mountings so the equipment is at proper elevation and level. Leave a space between pipe flanges equal to the expansion joint's face to face length shown on page 9•104. Install expansion joint and control rod assemblies. Control rod stop nuts should be finger tight against gusset plate. Lock in position with lock nut. Control rod assemblies will prevent extension of expansion joint & will not allow transfer of thrust load to spring supports of equipment and/or piping.

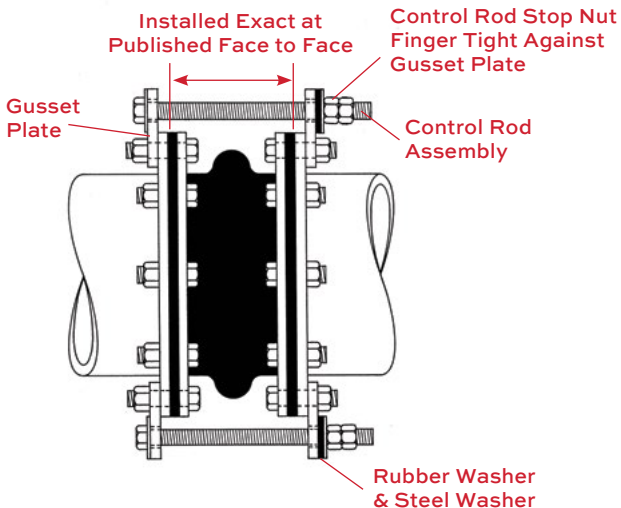

ANCHORED PIPING APPLICATIONS

Series 700 & HT700 expansion joints used to compensate for thermal movement in properly anchored & guided piping systems generally do not require control rods, provided piping movements are within the allowables shown on page 9•104.

If, as an added precaution, designers elect to use control rods in anchored systems, the expansion joint should be installed at its exact published face to face length. When control rod assemblies are installed, the stop nuts should be backed away from the gusset plate a distance equal to the allowable extension of the joint (See table, page 9•104). This will prevent overextension of the joint. Compression sleeves should also be employed. The compression sleeves are cut at the factory to the proper length to prevent over compression.

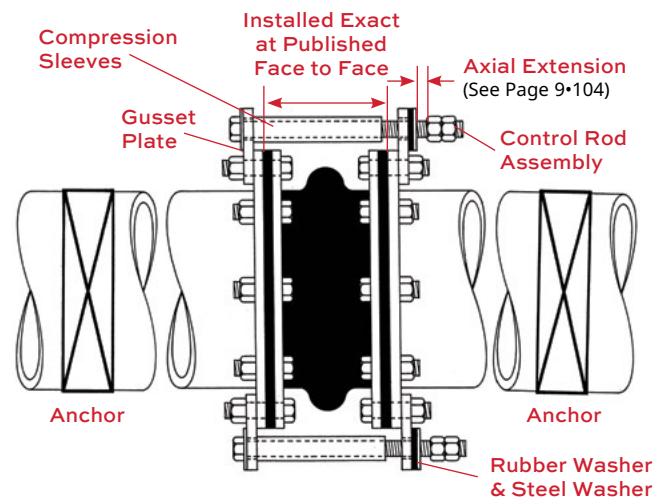

STYLE 700 & HT700 OPEN ARCH DIMENSIONS, ALLOWABLE MOVEMENTS* & PRESSURES†

Pipe Size (in)	Flange Outside Dia. (in)	Face to Face (in)	Overall Flange Thickness (in)		Bolt Circle Dia. (in)	No. of Holes	Bolt Hole Dia. (in)	Allowable Movements					Rated Working Pressure [‡] (psig)	Minimum Burst Pressure [‡] (psig)	Vacuum (in Hg)
			Steel	Ductile				Axial Compression (in)	Axial Extension (in)	Lateral Deflection (in)	Degrees Angular (degrees)	Degrees Torsional (degrees)			
1	4 1/4	6	7/8	1	3 1/8	4	1/2	11/16	3/8	1/2	20.0	3	165	660	30
1 1/4	4 5/8	6	7/8	1	3 1/2	4	1/2	11/16	3/8	1/2	19.0	3	165	660	30
1 1/2	5	6	7/8	1	3 7/8	4	1/2	11/16	3/8	1/2	18.5	3	165	660	30
2	6	6	7/8	1	4 3/4	4	5/8	11/16	3/8	1/2	14.5	3	165	660	30
2 1/2	7	6	7/8	1	5 1/2	4	5/8	11/16	3/8	1/2	11.5	3	165	660	30
3	7 1/2	6	7/8	1	6	4	5/8	11/16	3/8	1/2	10.0	3	165	660	30
4	9	6	7/8	1	7 1/2	8	5/8	11/16	3/8	1/2	7.5	3	165	660	30
5	10	6	7/8	1	8 1/2	8	3/4	11/16	3/8	1/2	6.0	3	150	600	30
6	11	6	7/8	1	9 1/2	8	3/4	11/16	3/8	1/2	5.5	3	150	600	30
8	13 1/2	6	7/8	1	11 3/4	8	3/4	11/16	3/8	1/2	5.0	3	150	600	30
10	16	8	7/8	1	14 1/4	12	7/8	11/16	3/8	1/2	4.5	3	150	600	30
12	19	8	7/8	1	17	12	7/8	11/16	3/8	1/2	3.8	3	150	600	30
14	21	8	1	1 1/8	18 3/4	12	1	11/16	3/8	1/2	3.3	2	90	360	30
16	23 1/2	8	1	1 1/8	21 1/4	16	1	11/16	3/8	1/2	2.8	2	70	280	30
18	25	8	1	1 1/8	22 3/4	16	1 1/8	13/16	7/16	1/2	2.5	1	70	280	30
20	27 1/2	8	1	1 1/8	25	20	1 1/8	13/16	7/16	1/2	2.5	1	70	280	30
22	29 1/2	10	1	1 1/8	27 1/4	20	1 1/4	15/16	1/2	1/2	2.3	1	70	280	30
24	32	10	1	1 1/8	29 1/2	20	1 1/4	15/16	1/2	1/2	2.0	1	70	280	30
26	34 1/4	10	1	1 1/8	31 3/4	24	1 1/4	15/16	1/2	1/2	2.0	1	60	240	30
28	36 1/2	10	1	1 1/8	34	28	1 1/4	15/16	1/2	1/2	2.0	1	60	240	30
30	38 3/4	10	1	1 1/8	36	28	1 1/4	15/16	1/2	1/2	2.0	1	60	240	30
34	43 3/4	10	1	1 1/8	40 1/2	32	1 1/2	15/16	1/2	1/2	1.8	1	60	240	30
36	46	10	1 1/8	1 1/4	42 3/4	32	1 1/2	15/16	1/2	1/2	1.5	1	60	240	30
40	50 3/4	10	1 1/8	1 1/4	47 1/4	36	1 1/2	15/16	1/2	1/2	1.5	1	60	240	30
42	53	12	1 1/8	1 1/4	49 1/2	36	1 1/2	11/16	9/16	1/2	1.5	1	60	240	30
44	55 1/4	12	1 1/8	1 1/4	51 3/4	40	1 1/2	11/16	9/16	1/2	1.5	1	60	240	30
48	59 1/2	12	1 1/8	1 1/4	56	44	1 1/2	11/16	9/16	1/2	1.3	1	60	240	30
50	61 3/4	12	1 1/8	1 1/4	58 1/4	44	1 3/4	11/16	9/16	1/2	1.3	1	60	240	30
54	66 1/4	12	1 1/8	1 1/4	62 3/4	44	1 3/4	11/16	9/16	1/2	1.3	1	60	240	30
56	68 3/4	12	1 1/8	1 1/4	65	48	1 3/4	11/16	9/16	1/2	1.3	1	60	240	30
60	73	12	1 1/8	1 1/4	69 1/4	52	1 3/4	11/16	9/16	1/2	1.0	1	60	240	30
66	80	12	1 1/8	1 1/4	76	52	1 3/4	11/16	9/16	1/2	1.0	1	60	240	30
72	86 1/2	12	1 1/8	1 1/4	82 1/2	60	1 3/4	11/16	9/16	1/2	0.9	1	50	200	30
78	93	12	1 1/8	1 1/4	88 3/4	60	2	11/16	9/16	1/2	0.9	1	50	200	30
84	99 3/4	12	1 1/8	1 1/4	95 1/2	64	2	11/16	9/16	1/2	0.8	1	50	200	30
90	106 1/2	12	1 1/8	1 1/4	102 1/4	68	2	11/16	9/16	1/2	0.8	1	50	200	30
96	113 1/4	12	1 1/8	1 1/4	108 1/2	68	2 1/4	11/16	9/16	1/2	0.7	1	50	200	30

*Reduce movements 50% when using filled arches.

†Higher pressure joints are special design, advise factory of requirements.

SERIES 700 HIGHER PRESSURE JOINTS

Size (in)	Rated Standard Working Pressure (psi)						Vacuum Rating (in Hg)
	700	710	720	730	740	750	
1-4	165	250	—	—	—	—	30
5-12	140	210	250	—	—	—	30
14	90	130	160	190	225	250	30
16-26	70	100	125	145	175	195	30
28-44	60	85	105	125	—	—	30
46-60	60	85	105	—	—	—	30
66-96	50	70	85	—	—	—	30

MATERIAL AVAILABILITY & OPERATING TEMPERATURES

SERIES 700

Series 700	Standard Materials Cover	Max Oper. Temp.
B	Butyl	250°F
E	EPDM	250°F
E	EPDM	300°F
H	Hypalon®	225°F
N	Neoprene	225°F
Ni	Nitrile	225°F
R	Natural	180°F
V	Viton®	250°F

SERIES HT700

Series HT700	High Temperature Material Cover	Max Oper. Temp.
K-E	EPDM	350°F
K-V	Viton®	400°F

Sizes 1 through 12 only.

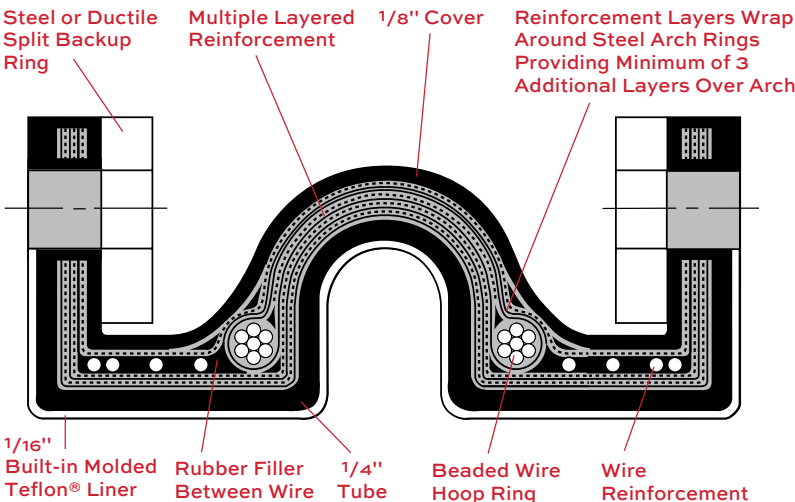

CAUTION

1. Do not install any of the products in this bulletin at pressures or temperatures higher than the published ratings.
2. Series 700 and HT700 must be installed against standard raised faced or flat faced flanges. Do not install them against recessed flanges such as Victaulic without calling the factory for proper steel filler flanges. If our rubber flanges do not have full bearing the expansion joint will be damaged and leak or fail.
3. Pipe system flanges must be smooth and flat. Screw in brass inserts such as those used in check valves can

damage the rubber faces if they project above the cast flange face.

4. Water type check valves must exactly center on the rubber flanges. Valve O.D. and I.D. must conform to raised face dimensions.
5. Use control rods as indicated on page 9-103.
6. Check Chemical Resistance Guide CRG-MR1, page 9-59, for service elastomer compatibility.
7. Follow installation instructions.

Installation Instructions - 700 & HT700**IMPORTANT**

- a. Do not weld in vicinity of expansion joint.
- b. Do not lift expansion joint by bolt holes; use padded sling.
- c. Never operate joint beyond its rated temperature, pressure or movements (See page 9-104).
- d. Mating flanges must be flat or raised face. Do not mate with contoured flanges such as victaulic or similar configurations.
- e. Check for chemical compatibility with the ordered material.

1. All pipelines must be properly supported, anchored and guided so joints do not carry pipe or thrust loads.
2. If piping is not anchored, control units must be used.
3. Use of control units and thrust sleeves will not protect piping in anchored situations. Expansion joints must be selected for adequate movement capability.
4. Piping should be aligned. Misalignment or improper face to face openings will reduce the allowable motion by the initial inaccuracy. Joints are often damaged if forced into position.
5. Apply a thin film of graphite, dispersed in glycerin or water to the rubber flange face and between the backup ring and the back of the rubber flange to prevent rubber adhering to the mating metal flange for easy removal of the joint without damage. No gaskets or gasket sealants should be used.
6. Install bolts from the backup ring side to avoid bolt projections cutting the cover. If this is impossible, bolts should not project more than 1/8" past the nuts. Use washers over split ring gaps.
7. Unlike tightening hard flanges, tighten bolts in series making at least three complete circuits of each flange. Flanges will accept full bolt torque.

8. After system is in service at operating temperature, check the flange bolts and retighten as necessary. Repeat in a few weeks or if leaks develop. It is normal for rubber flanges to relax after initial installation. Check periodically until bolts remain tight.
9. Any gouges or cuts in the cover caused during installation should be inspected and sealed.
10. If control rods are used, the clearance between the rubber washer and the gusset plate should be the allowable axial elongation, if the expansion joint is installed at the published face to face. We do not recommend precompression or extension as general practice, but if the joint is compressed, the gap is increased by the decrease in length. If installed elongated, the gap is decreased by the increase in length. Hold one end against the control rod plate and the washers against the nut on the other end when measuring the gap.

EXAMPLES

6" - 700 – Allowable Extension 3/8"

1. 6" - 700 is installed at published 6" face to face dimension.
Set control rod gap to 3/8".
2. 6" - 700 is installed 53/4" long.
Set control rod gap to 3/8" plus 1/4" = 5/8"
3. 6" - 700 is installed 61/4" long.
Set control rod gap to 3/8" minus 1/4" = 1/8"

11. If compression sleeves are used, no setting is required as they are furnished to proper length.
12. If these instructions are not strictly adhered to, the Mercer One-Year Guarantee is void. Joints should be checked at a maximum of one year intervals for signs of cracking and hardening. Expansion joints showing these symptoms must be replaced regardless of age.