

VIBRATION PADS

BRIDGE BEARING, RUBBER & CORK, RUBBER IMPREGNATED DUCK, NEOPRENE WAFFLE and NITRILE WAFFLE

**BBNR,
NK, HL,
W & NI**

Vibration Pads are used to reduce noise and vibration and to eliminate the need for bolting down. The flat configuration minimizes machine elevation. This low-cost method conveniently solves or prevents problems that do not warrant the use of either rubber or spring mountings. As a general rule, pads are recommended to eliminate high frequency noise, bolting, minor vibration problems in upper stories or for ground floor and non critical applications.

BBNR- BRIDGE BEARING PADS

We use the term "Bridge Bearing" as an indication of quality. All bearings that support bridges or highway overpasses use Neoprene or Natural Rubber compounds, so the molded product has high tensile and elongation characteristics and minimal permanent set or creep. Similarly, they must pass rigid tests for ozone and oxygen resistance.

When the pads are used for vibration isolation in supporting entire buildings, components such as structural floors or secondary floating floors, "Dynamic Stiffness" is another specified characteristic. This is important as the Dynamic Stiffness, Deflection and the shape of the Load Deflection curve control frequency.

Bearing pads are always solid pads (unlike our waffle pads), because loadings per square inch are high, often in the range of 1000 psi (70kg/cm²). BBNR Pads have a shallow waffle pattern on both faces to aid in gripping surfaces.

Capacities are controlled by area, hardness (durometer), thickness and perimeter relative to the loaded area.

Most of the time we design and mold these pads to specific requirements as explained in Architectural Bulletin **AB-104-3**, but we thought it would be helpful to offer some stock sizes for immediate shipment.

While they are used in acoustical applications, there is a constant demand for high capacity pads for pipe supports, structural supports, etc., in this load range.

Pads can be stacked with 1/8" (3mm) steel plates between them for higher deflections and greater efficiency. Higher loadings per square inch (cm²) require bonded inserts to avoid pancaking.



BBNR-
BRIDGE BEARING NATURAL RUBBER PADS

Type	Size		Max. Load		Max Defl.	
	(in)	(mm)	(lb)	(kg)	(in)	(mm)
BBNR-	10x10x1	250x250x25	25000	11340	1/8	3.2
	8x8x1	200x200x25	16000	7257		
	6x6x1	150x150x25	7900	3583		
	4x4x1	100x100x25	2400	1089		

NK- RUBBER & CORK SANDWICH PAD

Type "NK" pads are isolation sandwiches made by laminating a thick cork center core between two neoprene pads. This arrangement of the materials forces sound to pass through zones of different density with subsequent power losses because of the change in velocity. This pad is primarily recommended for acoustical rather than vibration problems when it is desirable to use a thick economical pad. Standard materials are loaded 50 psi (3.5 kg/cm²). Pads are 1" (25mm) thick and can be furnished 18" x 18" (450 x 450mm) or cut to exact size in addition to the tabulated sizes.

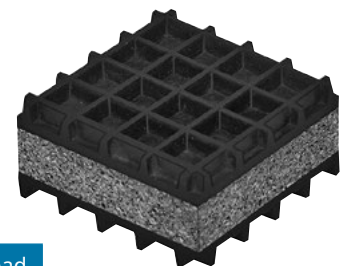

NK-
NEOPRENE & CORK PAD

Type	Size		Max. Load	
	(in)	(mm)	(psi)	(kg/cm ²)
NK-	18x18x1	450x450x25	50	3.5
	12x12x1	300x300x25		
	6x6x1	150x150x25		
	4x4x1	100x100x25		
	3x3x1	75x75x25		
	2x2x1	50x50x25		

HL- RUBBER IMPREGNATED DUCK PADS

Type "HL" pads are manufactured by impregnating layer on layer of woven cotton duck with natural rubber or neoprene. This process is carried on in a rubber press where the heat and pressure produces an extremely tough final product that is particularly suited to applications where alignment must be maintained. Typical applications are drop hammer anvil pads, printing press column supports, bridge roadway bearing pads, crane way supports, etc. Maximum loading is 1000 psi (70 kg/cm²). Pads are always furnished cut to size in the required thickness. The advantage of HL pads is consistent loading per square inch (cm²) unaffected by area, as capacity is dependent on the layers of cotton duck only.

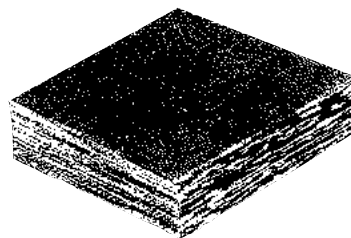

HL- RUBBER OR NEOPRENE DUCK PADS

Type	Thickness (in) (mm)	Max. Load (psi) (kg/cm ²)	
HL-	1/4 6	1000	70
	3/8 10		
	1/2 13		
	5/8 16		
	3/4 19		

W- NEOPRENE WAFFLE PADS

The Type "W" Neoprene Waffle Pad has greater carrying capacity per square inch, increased holding power and a built-in contamination seal. Identical rubber grids are molded back to back for maximum rubber contact area and resistance to rib collapse or hinging. The interconnections form suction pockets for gripping smooth steel as well as rough surfaces and also act as dirt and oil dams at the perimeter regardless of how the pad is cut. The square waffle pattern is laid out on 1/2" (13mm) centers to facilitate cutting pads to size in the field without the need for measuring with a tape measure.

While there is no need for bolting or cementing on most installations, Type "W" Adhesive may be used for securing machines that have exceptionally large horizontal forces. The adhesive is also useful when the pad is made part of an assembly or shipped cemented to machinery legs.

Waffle Pad is stocked in both 40 and 50 durometer Neoprene. The high tensile black stock has been selected for its oil resistance and physical specifications. Natural Rubber, Hycar, Butyl, Silicone or other of the Elastomers can be furnished for special conditions. Pricing would be dependent on material and quantity. Standard pads are 5/16" (8mm) thick and may be purchased 24" x 48" (600 x 1200mm), 24" x 24" (600 x 600mm), 18" x 36" (450 x 900mm), 18" x 18" (450 x 450mm) or cut to size.

W pads are often used in 2 or 3 layers cemented to 16 gauge steel plates between layers to form SWW wall supports. Assemblies are normally 6 ft (1.8m) long and 6, 8, 10 or 12" (150, 200, 250 or 300mm) wide to match wall width.

Waffle Pattern Top and Bottom

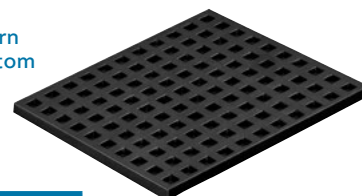

W- LOAD RATINGS

Type	Duro-meter	Recommended Loading (in) (mm)		Max. Load (psi) (kg/cm ²)	
W-	30	40	2.8	55	3.8
	40	60	4.2	85	6.0
	50	90	6.3	120	8.4
	60	120	8.4	170	12.0

SWW WALL ISOLATORS

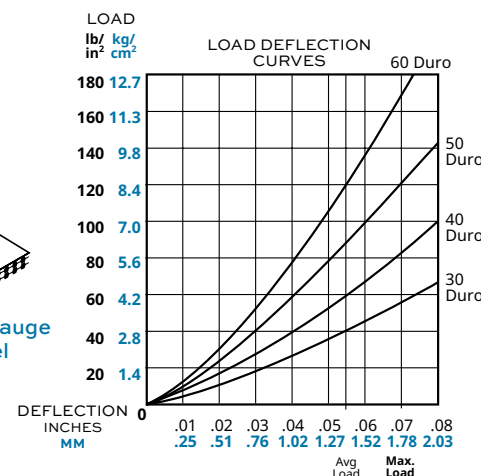
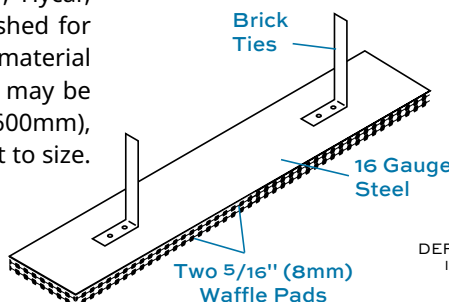

NI- NITRILE WAFFLE PADS

Nitrile has the best oil resistance of all the natural and synthetic rubber materials. It is superior to Neoprene and recommended for all locations where there is constant or intermittent exposure to oil, grease or gasoline.

Mason Type "Ni" Nitrile pads provide friction and avoid bolting as well as isolate vibration under:

- Drill presses
- Milling machines
- Shears
- Lathes
- Punch presses
- and similar machines

May be used in multi-layers separated by 16 gauge steel plates for greater efficiency.

Waffle Pattern Top and Bottom

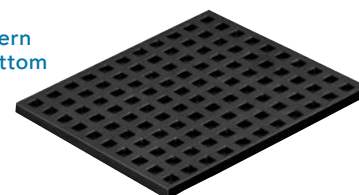

NI- NITRILE WAFFLE PADS

Type	Size (in) (mm)	Max. Load (psi) (kg/cm ²)		Thickness (in) (mm)	Color Code
NI-	18x18 450x450	50	3.5	5/16 8	Black
	6x6 150x150	50	3.5	5/16 8	Black
	18x18 450x450	100	7.0	5/16 8	Brown
	6x6 150x150	100	7.0	5/16 8	Brown
	18x18 450x450	200	14.0	5/16 8	Blue
	6x6 150x150	200	14.0	5/16 8	Blue
	18x18 450x450	280	19.7	1/2 13	Green
	6x6 150x150	280	19.7	1/2 13	Green