

COMPLETE HVAC ENGINEERING SPECIFICATIONS



VCS-100 remains unique, because there are engineering design explanations on the left hand side of each page to provide the reasons why we suggest the specification on the right. In personal meetings with thousands of engineers, this presentation has been invaluable in developing a broad understanding of quality design and application standards and why our isolators are built as they are.

None of our products are patented. There is no reason to accept an inferior cheapened substitute should a competitor have no pride in their product. We certainly hope that you find this tool useful and we continue to invite your comments as to its improvement.

All information is also available for download on our website at www.mason-ind.com.

TABLE OF CONTENTS

Explanation & Design Considerations with Individual Specification

Floor Mountings	2-9
Hangers & Horizontal Thrust Restraints	2-11
Bases	2-13
Roof Curbs	2-16
Flexible Connectors & Seals	2-17
Pipe Anchors	2-19
Riser Guides & Horizontal Pipe isolation	2-20
Pipe Riser Isolation	2-21
Duct Isolations	2-22

Complete Specifications

Specification Writing	2-22
Sample Isolator Schedule	2-23
Specification Selection Guide	2-24
Blower Minimum Deflection Guide	2-26
Guide Notes	2-26
Complete Specification	2-26
Specification Illustrations	2-30

To The Specifying Engineer:

In 1962 we introduced our first "HVAC Engineering Specification." While the 1962 approach was very well received and filled a void, it was made up of many individual specifications rather than presented in an organized format. It had no meaningful minimum static deflection guide and engineers found it hard to work with.

In 1965 we started the VCS series which was the first industry attempt to hone in on a specific group of HVAC products rather than the complete isolator range. It made it possible for the engineer to work with a small, versatile group of products and get to know them well. The 1965 specification included the first selection chart as an additional engineering tool highlighting the need for increased deflection in response to floor sensitivity and greater vibratory input from larger machines. These empirical suggestions written 35 years ago were based on 20 years of hands-on experience correcting bad installations on a guaranteed solution basis.

The 1965 series remained virtually unchanged until 1975, when we started publishing in the present format. The 1976, 1979 and 1982 modifications, all represented better explanations, product improvement or changes in the selection guide.

In this issue we have added air springs, sliding pipe guides, complete roof top spring curbs, DuPont™ Kevlar® reinforced expansion joints, completely engineered riser systems and changes in piping supports. Hopefully, our introduction of new

or improved methods will never stop. This new specification continues to incorporate the principles that have always been our guidelines.

1. The single degree of freedom mathematical Efficiency chart and equation is only a theoretical representation as it erroneously assumes great stiffness or mass under the isolators. This is not true in modern buildings. Older specifications called for a theoretical Isolation Efficiency that was usually inadequate for high speed and too conservative for low speed equipment. Static deflection requirements should be stated specifically and increased in keeping with floor deflections. For any given operating speed there will be a need for a larger spring deflection as the equipment is located in areas with longer unsupported spans because the floors become more flexible and vibration prone. Vibratory energy tends to increase with horsepower, so as a family of equipment such as pumps, become larger, there is need for more deflection. Once past a ratio of 3 between the operating speed and the natural frequency (bouncing frequency) of the spring system, vibration transmission is reduced in direct proportion to the increase in spring deflection.

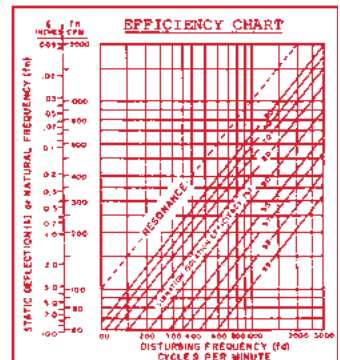

2. A spring isolator should be designed to utilize large diameter springs with a horizontal stiffness that is a minimum of 75% of the vertical. For all practical purposes, this can be verified if the outside spring diameter is not less than 0.8 of the compressed height of the spring at rated load. These springs require no housing for lateral stability. While housings may be required for other reasons, such as wind load or restraint when weight changes because of water drainage, housings must be designed so they do not influence the spring frequency in any direction during normal operation.
3. Steel bases should be made rigid to maintain the alignment of the equipment and resist both belt tension and torsional forces. It is also important that base members are stiff so they resonate at much higher frequencies than those generated by the isolated equipment. Base members that resonate at disturbing vibratory frequencies can seriously complicate the vibration problem. Steel encased concrete bases provide a simpler rigid design. While adding mass will reduce vibratory motion in direct proportion to the increase in total weight, all modern HVAC equipment can be mounted directly on steel bases without excessive motion. Therefore, concrete bases should be designed for stiffness as there is no need for additional mass.
4. Isolated equipment should be made as free to move as possible and not restricted by connected piping or ductwork. While this can be done with rigid piping having multiple bends and spring hanger suspension, we believe that flexible rubber connectors still remain the most fool proof method. To do this, Kevlar® reinforced double arch expansion joints are usually installed without control rods, either horizontally or vertically. If control rods must be used at very high pressures, the best mode is horizontal and parallel to the equipment shaft as they will only function radially. Flexible rubber connectors reduce noise and vibration at hydraulic pumping frequency (RPM x number of pump blades) but are ineffective at RPM.
5. Improper isolation of piping can bypass equipment support mountings. Therefore, mechanical piping should be treated as part of the machine and as much thought given to the piping

isolation as to the machinery itself. Since piping is subject to expansion and dynamic forces, sometimes there is need for compromise and we must provide resilient anchors to direct piping motion, and avoid pipe stress which might lead to pipe failure or damage to the structure. We do not believe that it is always practical to completely float a riser without providing resilient anchors when there are many branch-offs that tend to bind or offer unpredictable resistance.

In writing the VCS-100 specifications we have always tried to abide by the theory contained in our lecture to the ASHRAE Association and to temper this theory with studies of our successful installations and of even greater importance, record keeping of what had to be done to correct problem jobs, installed by our firm or others. The ASHRAE Lecture bulletin is immediately before this publication.

In earthquake zones the information provided by VCS-100 must be supplemented with some form of snubbing and preferably with snubbers that are selected with an eye to maximum movements and accelerations as the result of a computer study of the isolated machine and the earthquake that would affect it. Supplementary snubbing information can be found in our bulletin SCS-100 (page 3-23) and Specification Bulletins SVCS-110 Parts 1 and 2 (page 3-31).

Although engineers are generally more concerned with vibration transmission than airborne noise, there are those applications where airborne sound transmission is as important as vibration isolation. Information as to the proper design of floating floors, suspended ceilings and improved wall construction can be found in our architectural bulletin ACS-102 (page 4-3).

Since our first publication of VCS-100 in 1965, we have distributed over a million copies throughout the world. These presentations formalized specification writing in our industry and the greatest compliment is not only usage, but the fact that much of the information has been copied by our competitors. This new publication presents the specifications in print form, but it can also be downloaded as digital files off our web site. It can be used as written or edited to conform with your experience.

Very truly yours,
MASON INDUSTRIES, INC.



Norm Mason

Explanation & Design Considerations

Specifications

Floor Mountings

ND DOUBLE DEFLECTION NEOPRENE MOUNTINGS

See Bulletin ND-26 (page 6-3) for Complete Information.

Double deflection neoprene mountings and double deflection rails are recommended for minor equipment or basement locations only. We have placed this limitation on all rubberlike materials because of their relatively minor deflections.

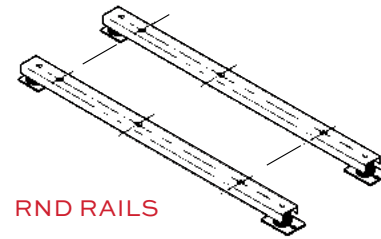
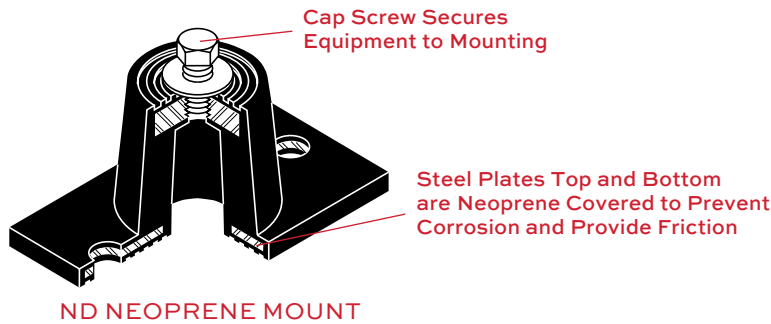

SPECIFICATION A

Neoprene mountings shall have a minimum static deflection of 0.35" (9mm). All metal surfaces shall be neoprene covered and have friction pads both top and bottom. Bolt holes shall be provided on the bottom and a tapped hole and cap screw on top. Steel rails shall be used above the mountings under equipment such as small vent sets to compensate for the overhang. Mountings shall be Type **ND** or rail Type **RND** as manufactured by Mason Industries, Inc.

SLF SPRING MOUNTINGS

See Bulletin SLF-200 (page 5-3) for Complete Information.

SLF spring mountings are our standard for all high efficiency installations. This is a bare spring design with a good ratio between the diameter and the working height to assure lateral stability. Our suggested specification states "that the spring diameter shall be no less than 0.8" (20mm) of the compressed height of the spring at rated load." This is easily checked in the submittal and review process. This minimum ratio will result in a horizontal stiffness no less than 3/4" (19mm) of the vertical, in virtually all cases. Should you be interested in the specifics of the design, please refer to bulletin SLF-200.

Some of our competitors are still publishing a minimum diameter chart rather than a ratio. This method of specification is questionable. If literally enforced, the call for a proprietary manufacturer's diameter would eliminate all competition. In reality, it is only the proportion of the spring that is important and this can only be expressed as a ratio rather than a specific size. For example, if a spring were specified 5" (127mm) in diameter and 5" (127mm) high with a spring constant of 1,000 lb/in, it would have about the same lateral stability as a spring 4" (102mm) in diameter and 4" (102mm) high designed with better quality spring steel capable of handling higher stresses as offered by another vendor.

The minimum 50% additional travel compensates for errors that creep in because of faulty weight data. This also means the springs will operate at lower stress which further guarantees their permanency. The neoprene friction pad on the bottom acts as a sound break for some high frequencies which may travel down the spring wire. The pad also eliminates the need for bolting in virtually all applications. Bolting is preferable on steel or overhead locations.

SPECIFICATION B

Spring isolators shall be free standing and laterally stable without any housing and complete with a molded neoprene cup or 1/4" (6mm) neoprene acoustical friction pad between the baseplate and the support. All mountings shall have leveling bolts that must be rigidly bolted to the equipment. Installed and operating heights shall be equal. The ratio of the spring diameter divided by the compressed spring height shall be no less than 0.8" (20mm). Springs shall have a minimum additional travel to solid equal to 50% of the rated deflection. Submittals shall include spring diameters, deflection, compressed spring height and solid spring height. Mountings shall be Type **SLF**, as manufactured by Mason Industries, Inc.

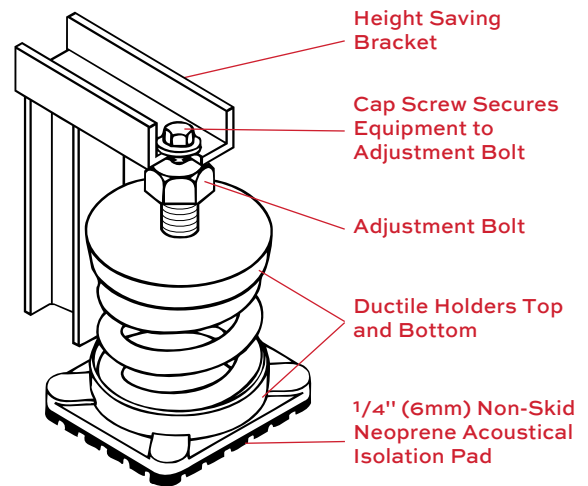

SLF SPRING MOUNT

MT AIR SPRING MOUNT

See Data Sheet DS-205 (page 5-47) for Complete Information.

It is possible to reach frequencies as low as 84 cpm (1.4hz) or even lower using steel springs and provide excellent isolation at RPM or the fundamental frequency, but noise transmission is another issue. The high pitched whines and hums developed by very high speed centrifugal, screw and sometimes reciprocating compressors, as well as transformers, travels axially through the spring wire and comes through the bottom spring coil with little reduction. While a rubber pad will reduce this noise, it has been our experience on many occasions that no matter how many layers of rubber pads were used (we have built up to 6" (152mm)), the noise will still find its way through. We never use pads harder than 60 durometer, but harder pads (65 duro and higher) are even more sound transparent.

Air springs completely eliminate this problem. Support is provided by pressurized air within a thin walled rubber container similar to but lighter than the side walls of an automobile tire. We have never experienced high frequency noise transmission when using air springs, as the sound is not transmitted by the air or the tire cord reinforced neoprene body.

There is always some air leakage no matter how slow. After systems are installed, they are seldom inspected and maintained. Our experience has proven it is mandatory that the air springs are installed with an air supply and height sensitive (not pressure sensitive) control valves. The valves provide additional air if elevation is lost or vent if the elevation increases due to rotational forces or temperature increase. Temperature increases occur on hot roofs or within transformer vaults.

Air usage is minimal. Most of the time the system is supplied by control air. If not available, the smallest available tank type compressor is more than adequate if it will operate at the air spring rated pressure. This compressor is often mounted on the primary equipment so it is self isolated.

We strongly recommend air springs in critical areas where noise transmission is a major worry.

SPECIFICATION C

Multiple bellow air springs shall be manufactured with powder-coated upper and lower steel sections connected by a replaceable, flexible Nylon reinforced Neoprene element to achieve a maximum natural frequency of 3 Hz. (We have found 3 Hz adequate when using air springs. Should the specifying engineer require a lower frequency, change the 3 Hz to the lower number.) Burst pressure must be a minimum of 3 times the published maximum operating pressure. All air spring systems shall be equipped with 3 leveling valves connected to the building control air or a supplementary air supply to maintain elevation plus or minus 1/8" (3mm). An air filter and water separator shall be installed before the air distribution system to the leveling valves.

Submittals shall include natural frequency, as well as load and damping tests, all as performed by an independent lab or acoustician. Air springs shall be Type **MT** and leveling valves Type **LV** as manufactured by Mason Industries, Inc.

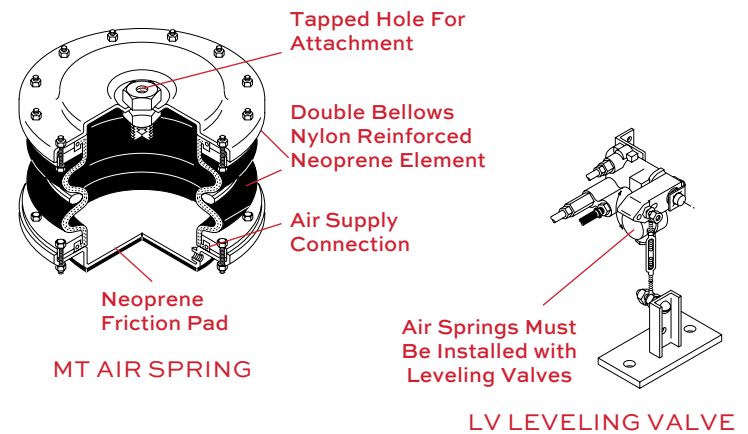

SLR & SLRSO RESTRAINED MOUNTINGS

See Bulletin SLR-220 (page 5-34) & Data Sheet DS-224 (page 5-30) for Complete Information.

SLR and SLRSO restrained mountings limit upward travel when weight is temporarily removed and provide safety stops for windy rooftop applications. All mountings are shipped with removable steel spacers between the sides and the top plate of the mounting as shown in the illustration. When the spacer is in place, the mountings are rigid blocks that support the equipment at elevation before spring adjustment. After the springs are adjusted to take the load, the spacers are removed to provide the operating clearance without changing the height of the mounting. The stop nut is adjusted to provide a clearance of 1/8" (3mm) to complete the adjustment. When there is a radical weight change, such as the water and refrigerant being removed from a chiller, the water drained from a steam generator or a cooling tower, the upward spring expansion is limited by the clearance under the stop nut.

In extremely windy situations, overturning is limited to this same movement plus the downward movement of the mountings on the opposite side. In most countries, other than those experiencing storms with higher velocities, designs are based on 100 miles per hour winds which exert a pressure of 30 lb/ft² on the equipment. The force can be calculated using the largest vertical surface to check whether the housing rating of the mountings is adequate, both horizontally and vertically.

The call out of minimum clearance around the restraining bolts is very important, since it offers some assurance that the springs will not be short circuited when there is minor misalignment of the housings because of structural tolerances in the steel work or attachments. SLR's and SLRSO's are used under chillers and steam generators as well as roof top equipment such as cooling towers, heating and ventilating units and blowers. They are often used as pipe horizontal supports as well, because the upper steel surface facilitates stanchion attachment.

SPECIFICATION D

Equipment with large variations in the operating and installed weight, such as chillers, boilers, etc., and equipment exposed to the wind such as cooling towers, roof mounted fans and roof mounted air handling equipment shall be mounted on spring mountings, as described in Engineering Specification B, including the neoprene acoustical pad within a rigid housing that includes vertical limit stops to prevent spring extension when weight is removed and temporary steel spacers between the upper and lower housings. Housings shall serve as blocking during erection. When the equipment is at full operating weight, the springs shall be adjusted to assume the weight and the spacers removed, without changing the installed and operating heights. All restraining bolts shall have large rubber grommets to provide cushioning in the vertical as well as horizontal modes. The hole through the bushing shall be a minimum of 3/4" (19mm) larger in diameter than the restraining bolt. Horizontal clearance on the sides between the spring assembly and the housing shall be a minimum of 1/2" (13mm) to avoid bumping and interfering with the spring action. Vertical limit stops shall be out of contact during normal operation. Cooling tower mounts are to be located between the supporting steel and the roof or the grillage and dunnage as shown on the drawings when there is no provision for direct mounting. Housings and springs shall be powder coated and hardware electro-galvanized. Mountings shall be Type **SLR** or **SLRSO** as manufactured by Mason Industries, Inc.

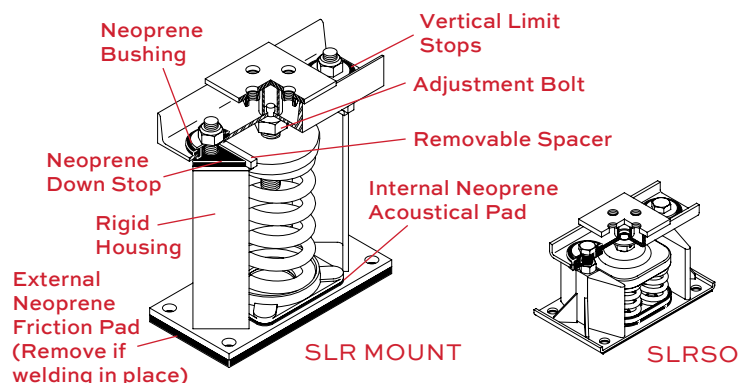

Explanation & Design Considerations

Specifications

SLR-MT RESTRAINED MOUNTINGS

See Data Sheet DS-206 (page 5-51) for Complete Information.

SLR-MT restrained mountings contain MT air springs in place of the SLF springs in the SLR mountings. The steel housing around the MT air spring serves exactly the same purpose as the SLR housing in explanation D. SLR-MT are recommended in lieu of SLR in highly critical situations as described for the MT.

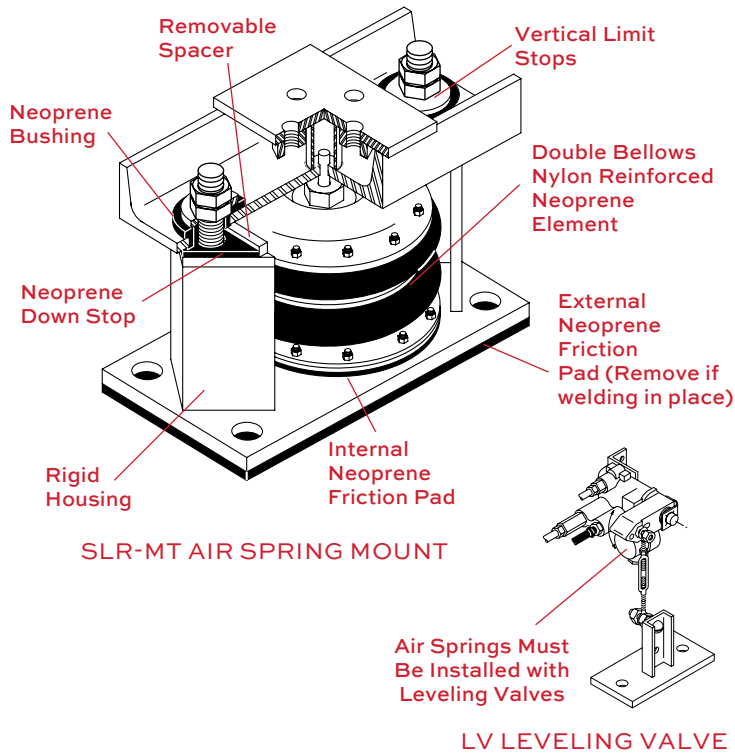

SPECIFICATION E

Equipment with large variations in the operating and installed weight, such as chillers, boilers, etc., and equipment exposed to the wind such as cooling towers, roof mounted fans and roof mounted air handling equipment shall be mounted on air springs, as described in Engineering Specification C, but within a rigid housing that includes vertical limit stops to prevent spring extension when weight is removed and temporary steel spacers between the upper and lower housings. Housings shall serve as blocking during erection. When the equipment is at full operating weight, the air springs shall be pressurized to take the weight so the spacers can be removed without changing the installed and operating heights. All restraining bolts shall have large rubber grommets to provide cushioning in the vertical as well as the horizontal modes. The hole through the bushing shall be a minimum of 3/4" (19mm) larger in diameter than the restraining bolt. Horizontal clearance between the air spring assembly and the housing shall be a minimum of 1/2" (13mm) to avoid bumping and interference with the air spring action. Vertical limit stops shall be out of contact during normal operation. Mountings and air spring parts shall be powder coated. Hardware electro-galvanized. Air spring systems shall be connected to the building control air or a supplementary air supply and equipped with three leveling valves to maintain level within plus or minus 1/8" (3mm). Cooling tower mounts are to be located between the supporting steel and the roof or the grillage and dunnage as shown on the drawings when there is no provision for direct mounting. Mountings shall be Type **SLR-MT** and leveling valves Type **LV** as manufactured by Mason Industries, Inc.

Hangers

30N HANGER

See Bulletin H-610 (page 7-3) for Complete Information.

We have worked with combination spring and neoprene hangers for over 45 years, the springs for vibration and the neoprene for noise. Our older and competitor's designs had the common fault of not allowing enough angular hanger rod misalignment. Where the rod passes through the hole, it would strike the hanger box and short circuit the spring. To solve the problem, we designed a new spring series, short and larger in diameter so we could enlarge the hole in the bottom of the hanger box. Another improvement was molding a LDS* Rubber cup to socket the spring and provide a protective bushing where the rod passes through the hanger box and replacing the neoprene hanger element with the same material. The 30° requirement is a way of describing this clearance. The callout of a scale drawing of the hanger to show this capability is the only assurance that no one will submit a look alike that does not have this important capability.

*LDS stands for Low Dynamic Stiffness Natural Rubber. It has a substantially lower frequency than neoprene at a given deflection and a better life span as well.

SPECIFICATION F

Hangers shall consist of rigid steel frame containing a minimum 1 1/4" (32mm) thick LDS rubber element at the top and a steel spring with general characteristics as in Specification B seated in a steel washer reinforced LDS rubber cup on the bottom. The LDS rubber element and the cup shall have molded bushings projecting through the steel box. In order to maintain stability the boxes shall not be articulated as clevis hangers nor the LDS rubber element stacked on top of the spring. Spring and hanger lower hole diameters shall be large enough to permit the hanger rod to swing through a 30° arc from side to side before contacting the cup bushing and short circuiting the spring. Submittals shall include a hanger drawing showing the 30° capability. Hangers shall be Type **30N** as manufactured by Mason Industries, Inc.

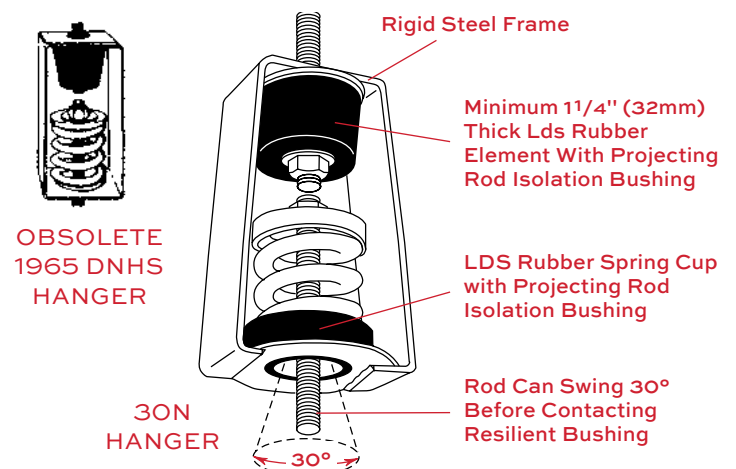

Explanation & Design Considerations

PC30N HANGERS

See Bulletin H-610 (page 7-3) for Complete Information.

While hanger adjustment along the run of a pipe may not be too critical, it is important that the pipe weight is kept off isolated equipment in order to maintain alignment, protect cast flanges and flexible hoses. Should the piping weight fall on the equipment, the floor mountings become overloaded and inoperative. Back in 1965, we called for a Type PDNHS hanger. This design did not have clearances as described in Specification D for the new 30N and our method of maintaining the elevation was to build the hanger with a firm platform above the spring and then to ask the contractor to follow the procedure of loading the spring and ultimately relieving this upper nut. This was very difficult to do, and in many cases it was not done at all, so the hangers remained solid hangers. While a theoretical specification may be convincing, we are all interested in performance so there was no point in continuing to call for a device that could not be adjusted properly.

Therefore, we changed the specification to call for the Type PC30N as illustrated. Rather than a rigid secondary platform, we preload this hanger in our factory so that it is shipped with the rated deflection shown on the indicator. It remains a constant elevation device because the springs do not deflect additionally when the contractor adds the load. In order to make the hanger operative, he does not have to "wind up" the spring, but merely to release the spring by unlocking the nut at the bottom. If our assumed weight is incorrect, there will be a very minor upward movement as the spring assumes the exact load. While these hangers do not do the job as precisely as the old design, they are much less expensive to install and for all practical purposes the systems will be much better for our having made this change in our recommendations, as all hangers will be functional.

There is a strong need for these hangers near the equipment and that is the reason that we call for the first four hangers to be Type PC30N. They are also recommended for other situations, where you want a precise installation. They are particularly useful when hanging pipe that is 6 inches in diameter and larger, as they keep the pipe run level as the installation proceeds. When a contractor uses a standard hanger that deflects as pipe is added, it is very difficult to put large pipe in properly. In many cases, the contractor will install solid rods to begin with and then cut the rods and install the spring hangers later. This is a very expensive procedure that can be eliminated by using pre-compressed hangers throughout. It is a matter of economics.

In our specification, we call for this design for the first four hangers from the equipment (30 ft (9m)). You can modify that requirement plus or minus should you edit our specification.

30 & W30 HANGERS

See Bulletin CH-620 (page 7-25) for Complete Information.

The W30 hanger is satisfactory for duct isolation since ducts vibrate at lower frequencies than piping and there is no high frequency component requiring a full LDS Rubber element. This simple spring hanger retains the 30° capability, but the housing is manufactured so that it may be attached to flat straps rather than rods. If rods are used rather than flat straps, the Type 30 serves the same purpose.

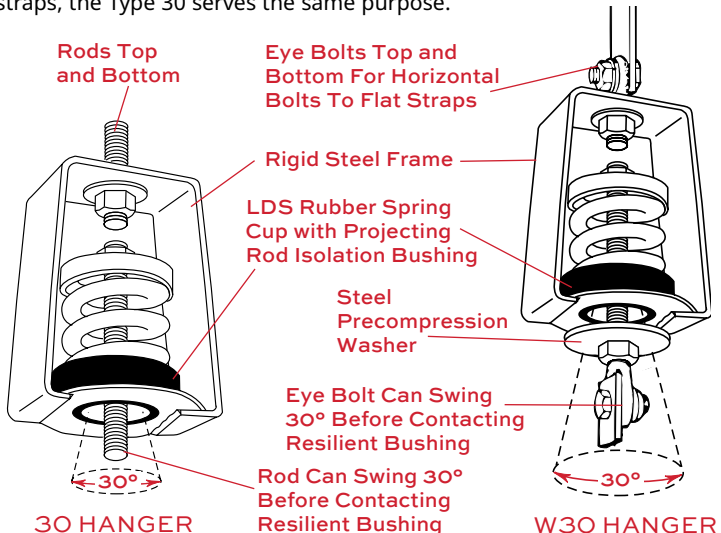

Specifications

SPECIFICATION G

Hangers shall be as described in F, but they shall be precompressed and locked at the rated deflection by means of a steel precompression washer to keep the piping or equipment at a fixed elevation during installation. The hangers shall be designed with a release mechanism to free the spring after the installation is complete and the hanger is subjected to its full load. Deflection shall be clearly indicated by means of a scale. Submittals shall include a drawing of the hanger showing the 30° capability. Hangers shall be Type **PC30N** as manufactured by Mason Industries, Inc.

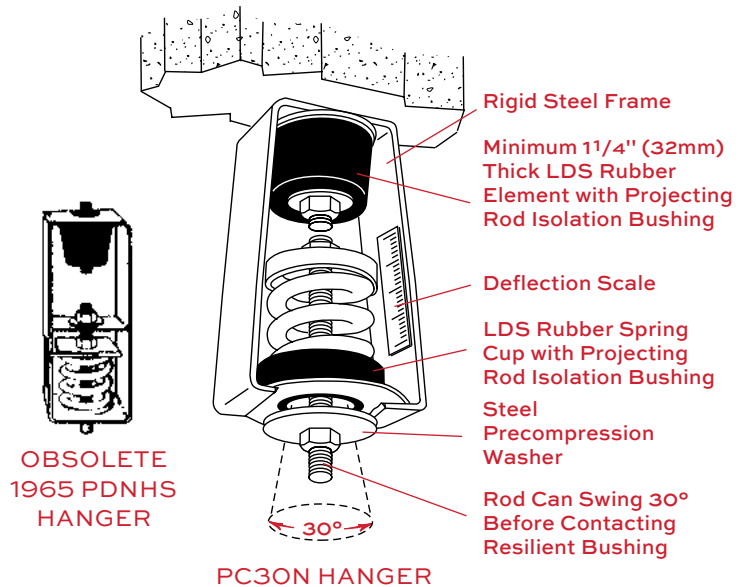

NOTE: LDS stands for Low Dynamic Stiffness Natural Rubber.

SPECIFICATION H

Hangers shall be manufactured with minimum characteristics as in Specification B, but without the LDS Rubber element. Springs are seated in a steel washer reinforced LDS Rubber cup molded with a rubber bushing projecting through the bottom hole to prevent rod to hanger contact. Spring diameters and the lower hole sizes, shall be large enough to allow the hanger rod to swing through a 30° arc from side to side before contacting the cup bushing.

If ducts are suspended by flat strap iron, the hanger assembly shall be modified by the manufacturer with an eye on top of the box and on the bottom of the spring hanger rod to allow for bolting to the hanger straps. Submittals on either of the above hangers shall include a scale drawing of the hanger showing the 30° capability. Hangers for rods shall be Type **30** or for straps Type **W30** as manufactured by Mason Industries, Inc.

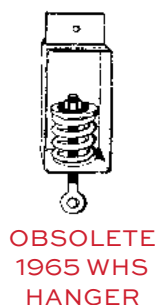

Horizontal Thrust Restraints

WB HORIZONTAL THRUST RESTRAINT

See Data Sheet DS-2075 (page 5-23) for Complete Information.

It is not unusual to encounter problems where the horizontal combined air thrust exceeds 10% of the equipment weight. If the spring columns alone resist a 10% force, they will lean over about 12% of the rated deflection. This is the recommended maximum.

When the thrust is higher, the best solution is adding mass to bring the ratio back down to 10%. If adding mass is impractical, horizontal restraints are another possibility. This is particularly true of fan heads, but high pressure axial and centrifugal fans may present the same problem. The equipment may be hung or floor mounted. Our horizontal restraint is a modified spring hanger with a precompression adjustment to limit movement when the system starts and stops and the air pressure builds up or dies off, as explained in the specification.

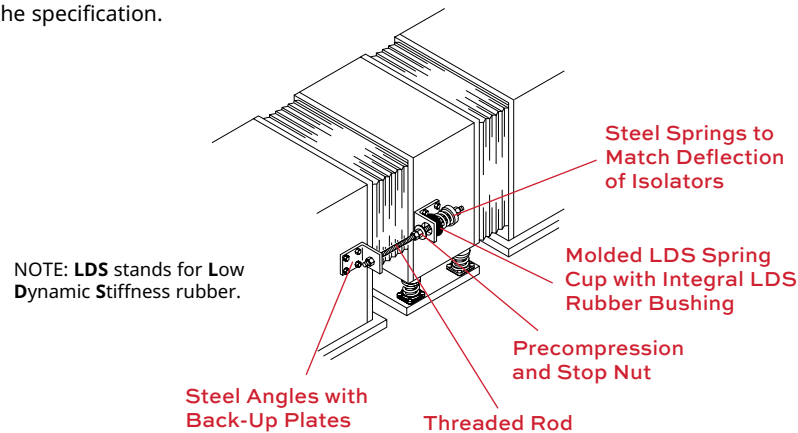

WB HORIZONTAL THRUST RESTRAINTS

SPECIFICATION I

When total air thrust exceeds 10% of the isolated weight, floor mounted or suspended air handling equipment shall be protected against excessive displacement by the use of horizontal thrust restraints. The restraint shall consist of a modified Specification B spring mounting. Restraint springs shall have the same deflection as the isolator springs. The assembly shall be preset at the factory and fine tuned in the field to allow for a maximum of 1/4" (6mm) movement from stop to maximum thrust. The assemblies shall be furnished with rod and angle brackets for attachment to both the equipment and duct work or the equipment and the structure. Restraints shall be attached at the center line of thrust and symmetrically on both sides of the unit. Horizontal thrust restraints shall be Type **WB** as manufactured by Mason Industries, Inc.

Bases

WF STEEL BEAM BASE

See Data Sheet DS-800 (page 8-3) for Complete Information.

Our very early specifications merely called for "sufficient base rigidity" to handle belt tension and keep the drive in alignment. There had been no criteria for base stiffness or design and every vendor had his own version of what might be minimally acceptable as there never was a unified code. Pump bases have torque and bending problems that can ruin bearings, couplings and pump seals. Before we extended pump bases to support elbows, many installations were short circuited with suction and discharge dog legs to the floor. We discussed this problem with a number of structural people as well as acoustical specialists and found that using beams with a depth equal to 1/10th of the span is a good broad working rule that can be readily checked in the submittal stage. We have manufactured thousands of these bases and find the design highly satisfactory as to appearance, rigidity and keeping base resonance high. The 14" (356mm) limit on beam depth came about because experience has shown that the 1/10 requirement is too severe on very large bases. For example, in the 1965 specification, without this limitation, we encountered situations where the distance between chiller legs was 20 ft (6m). Thus, the specification was calling for 24" (610mm) beams under a machine that already had great structural rigidity. In other situations, heating and ventilating units might be as long as 15 ft (4.5m). Thus, it would seem that 18" (457mm) beams should be used, but these were completely excessive as the whole unit might only weigh 8,000 lb (3636 kg). The 14" (356mm) limitation makes the specification more practical.

SPECIFICATION J

Vibration isolation manufacturer shall furnish integral structural steel bases. Rectangular bases are preferred for all equipment. Centrifugal refrigeration machines and pump bases may be T- or L-shaped. Pump bases for split case pumps shall be large enough to support suction and discharge elbows. All perimeter members shall be steel beams with a minimum depth equal to 1/10 of the longest dimension of the base. Base depth need not exceed 14" (356mm) provided that the deflection and misalignment is kept within acceptable limits as determined by the manufacturer. Height saving brackets shall be employed in all mounting locations to provide a base clearance of 1" (25mm). Bases shall be Type **WF** as manufactured by Mason Industries, Inc.

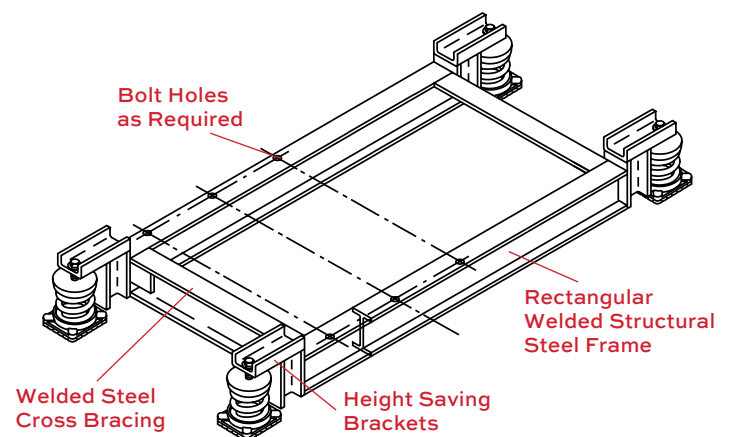

WF STEEL BEAM BASE

Explanation & Design Considerations

SADDLES & BRACKETS

A complete steel base is not required for equipment such as Absorption Machines, Reciprocating Compressors, Shell Mounted Centrifugal Compressors, H&V units, etc. Steel members improve stability, lower operating heights and in the case of H&V units prevent distortion of sheet metal legs or base angles. The use of saddles and brackets represents a cost saving compared to the complete bases in Specification J. We have called for Specification K in the Selection Guide for all locations without J or L bases when B or D mountings have 2 1/2" (64mm) deflection or more to improve appearance and reduce elevation. Never use independent cross members in Seismic Zones, because of rotational failure. Always use complete bases.

K CONCRETE WELDED BASES & BMK CONCRETE BOLTED BASES

See Bulletin B-840 (page 8-6) for Complete Information.

Concrete bases are recommended under pumps as they are more rigid and a better choice in maintaining alignment. They need not be selected for the additional mass that is needed under highly unbalanced machines such as slow speed horizontal or vertical compressors. If the building can handle the added weight, floating concrete installations always look better and the shielding reduces air borne noise transmission. The K designs are a neat way of building these bases as the contractor receives a complete package consisting of a steel form with reinforcing bars and anchor bolt templates in place ready for pouring. Concrete foundations need not have quite the same depths as steel bases since stiffness is provided by the entire width. Therefore, we have reduced the depth requirement to 1/12 the longest dimension. We have limited the mandatory depth to 12" (305mm), as compared to our older specification which had no depth limit. If the vibration manufacturer feels that the 12" (305mm) depth is not sufficient, he may increase it at his option. An open ended requirement of 1/12 of the longest dimension led to thicknesses that were completely impractical on long bases where there was no particular alignment, inertial or loading problem.

The steel form may be bolted or welded, structural or formed metal if it does not deform during the pour. When the concrete hardens, the structural strength and rigidity is provided by the reinforcement and has little or nothing to do with the perimeter steel.

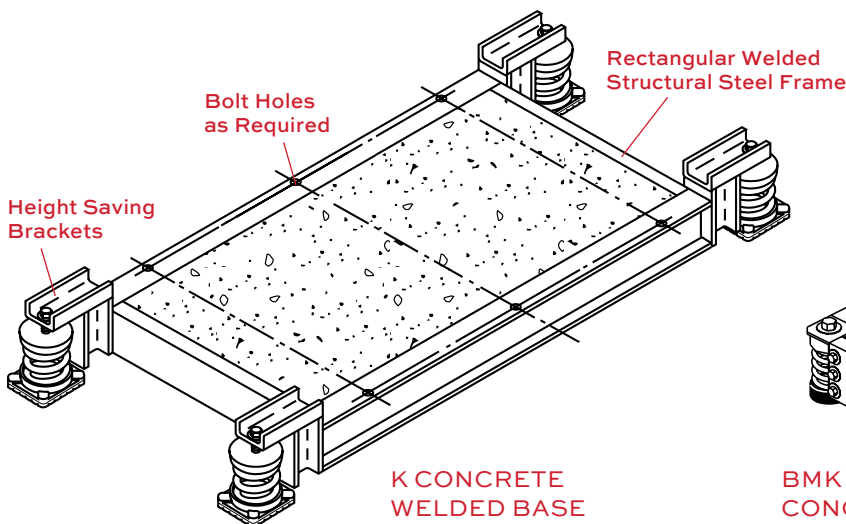

Specifications

SPECIFICATION K

Vibration isolation manufacturer shall provide steel members welded to height saving brackets to cradle equipment having legs or bases that do not require a complete supplementary base. Members shall have sufficient rigidity to prevent distortion of equipment. Inverted saddles shall be Type **ICS**, as manufactured by Mason Industries, Inc.

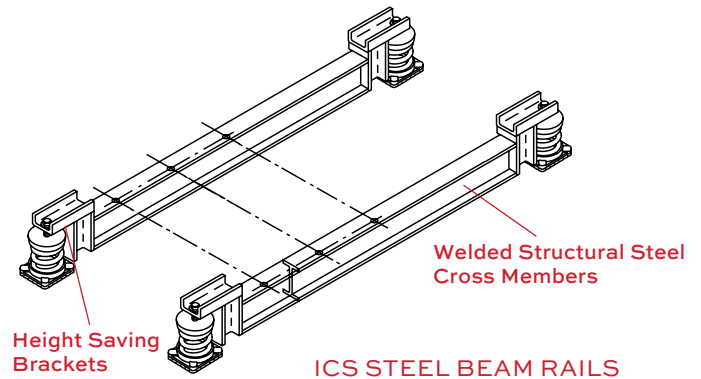

SPECIFICATION L

Vibration isolation manufacturer shall furnish rectangular steel concrete pouring forms for floating concrete bases. Bases for split case pumps shall be large enough to provide support for suction and discharge elbows. Bases shall be a minimum of 1/12 of the longest dimension of the base but not less than 6" (152mm). The base depth need not exceed 12" (305mm) unless specifically recommended by the base manufacturer for mass or rigidity. Forms shall include minimum concrete reinforcing consisting of 1/2" (13mm) bars welded in place on 6" (152mm) centers running both ways in a layer 1 1/2" (38mm) above the bottom. Forms shall be furnished with steel templates to hold the anchor bolt sleeves and anchor bolts while concrete is being poured. Height saving brackets shall be employed in all mounting locations to maintain a 1" (25mm) clearance below the base. Wooden formed bases leaving a concrete rather than a steel finish are not acceptable. Base shall be Type **BMK** or **K** as manufactured by Mason Industries, Inc.

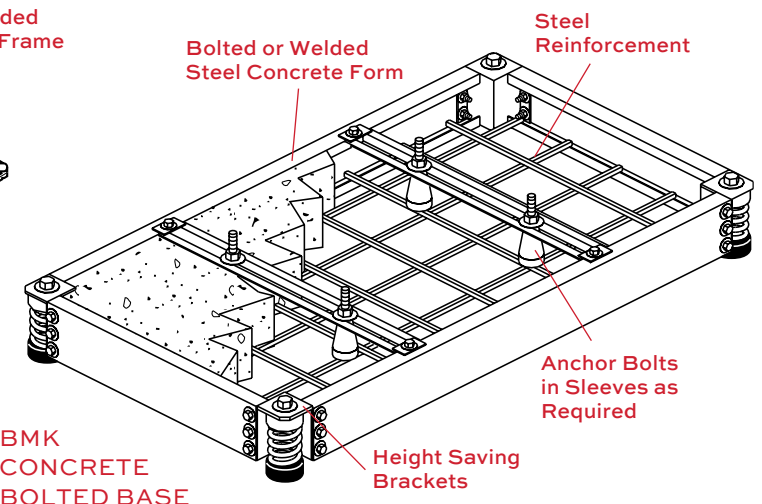
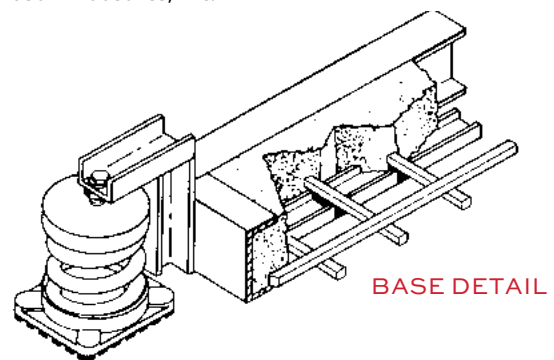

Explanation & Design Considerations

Specifications

Curb Mounted Aluminum Bases Nominal 1" (25mm) Deflection

CMAB MOUNTED ALUMINUM BASE

See Bulletin B-830 (page 8-12) for Complete Information.

Not too many years ago, cooling towers and curb mounted exhaust fans were the only pieces of mechanical equipment to be found on rooftops. This has all been changed as curb mounted air conditioning equipment is commanding a larger share of the market. While rooftop equipment manufacturers do what they can to isolate components within their packages, their effectiveness is limited by shipping problems and available space as well as piping, electrical and fan connections. Unfortunately, many roofs are extremely sensitive to vibration and this makes the problem more difficult than can be handled by the manufacturer's efforts.

Curb mounted isolation bases must:

1. fit on top of manufacturers standard curbs and match the underside of the isolated equipment.
2. have wind and water seals that do not interfere with the spring action.
3. resist wind forces and aging.
4. provide as much static spring deflection as practical.

As with most of our products, all of these things had been done by custom building bases in the field to solve existing problems and this led to the design of our Curb Mounted Aluminum Base (Type CMAB). We wasted a great deal of time with various friction and shear seals and we should have known better. All of our other products never worked properly until we had a free standing spring system and curbs were no exception.

The SLF Spring Mountings are better than the Type C telescoping castings because the few inches of soft sponge guiding material in the Type C often interferes with the action of the springs as happens with all telescoping designs, regardless of manufacturer. In trying to use this method for sealing roof bases, some 16 to 60 lineal feet (4.8m to 7.2m) of sponge was needed for the perimeter and the binding or freezing of the two members can completely bypass the spring isolation. Therefore, we eliminated this method and our weather seal is a truly flexible EPDM duct like seal rather than a sliding or shear fit. As a secondary precaution, the upper aluminum member overlaps the lower and acts as a water shield.

The main members of these bases are made of extruded aluminum, welded in the corners for weather-tightness. All of the steel springs are zinc electroplated or powder coated. Whenever practical, bases are shipped in one welded assembly to minimize assembly and installation time in the field. Where size does not permit one piece shipment, we minimize the number of joints and furnish simple splice kits.

Horizontal wind resistance is provided by the horizontal spring stability and supplementary rubber pads located between the two frames in the corners. There is adequate clearance between upper and lower frames and the snubbers only act during high wind.

Springs are selected from our standard A series with a rated minimum deflection of 1" (25mm) or more and 50% overtravel. Occasionally, we attain 1 1/4" (32mm) deflection by using more of the lightest springs in the series, but this is uneconomical except for very light equipment. The suggested specification calls for minimum 3/4" (19mm) deflection as the manufacturer's weight and CG data may be inaccurate and we do not wish to overstate the CMAB capability. While it would be desirable to use a higher deflection series than the 1" (25mm) the design is limited by curb width and equipment contact problems. The use of taller springs having the same diameter would lead to higher deflections on paper, but the much lower horizontal stability and consequent rubbing would lower rather than improve overall performance.

CMAB curb mounted rooftop equipment bases are an excellent 1" (25mm) nominal 3/4" (19mm) deflection tool and added insurance for this type of installation on top of new buildings.

CMAB curbs should not be used in seismic zones higher than 2A.

SPECIFICATION M

Curb mounted rooftop equipment shall be mounted on vibration isolation bases that fit over the roof curb and under the isolated equipment. The extruded aluminum top member shall overlap the bottom to provide water runoff independent of the seal. Aluminum members shall house electro-galvanized or powder coated springs selected for 3/4" (19mm) minimum deflection. Travel to solid shall be 1 1/2" (38mm) minimum. Spring diameters shall be no less than 0.8 of the spring height at rated load. Wind resistance shall be provided by means of resilient snubbers in the corners with a minimum clearance of 1/4" (6mm) so as not to interfere with the spring action except in high winds. Manufacturer's self-adhering closed cell sponge gasketing must be used both above and below the base and a flexible EPDM ductlike connection shall seal the outside perimeter. Foam or other sliding or shear seals are unacceptable in lieu of the EPDM ductlike closure. Submittals shall include spring deflections, spring diameters, compressed spring height and solid spring height as well as seal and wind resistance details. Curb mounted bases shall be Type **CMAB** as manufactured by Mason Industries, Inc.

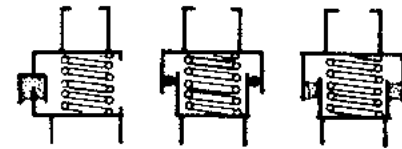

UNSUCCESSFUL FRICTION
AND SHEAR SEALS

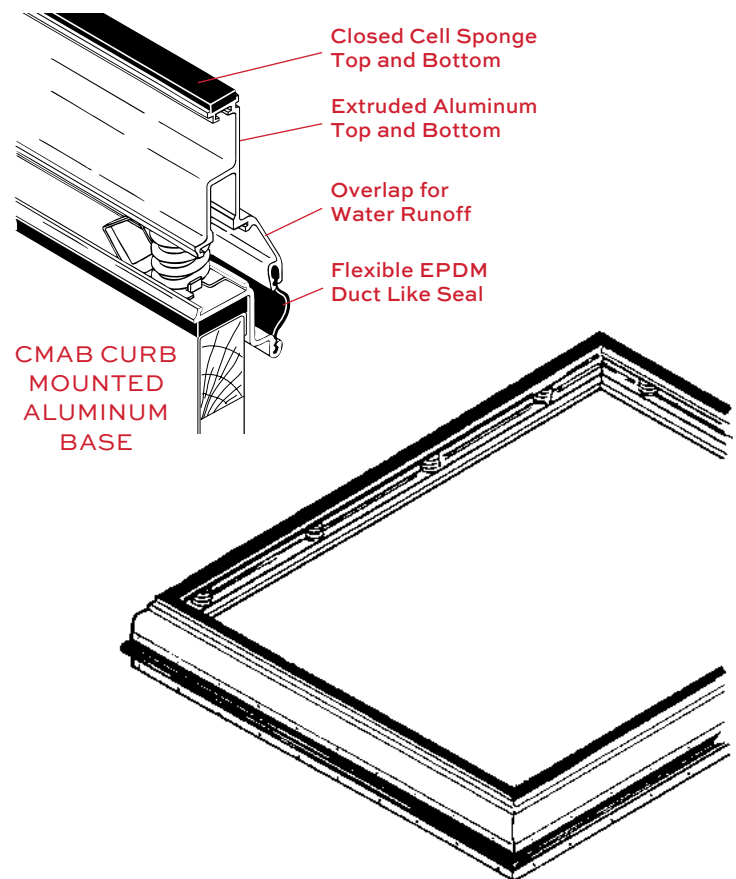

CMAB CURB
MOUNTED
ALUMINUM
BASE

Complete Rooftop Spring Curbs

RSC COMPLETE ROOFTOP SPRING CURBS

See Bulletin RSC-22 (page 8-15) for Complete Information.

In 1982 we showed the following method for increasing deflection by suspending units from springs on top of a steel frame work and using the CMAB curb without springs as the seal.

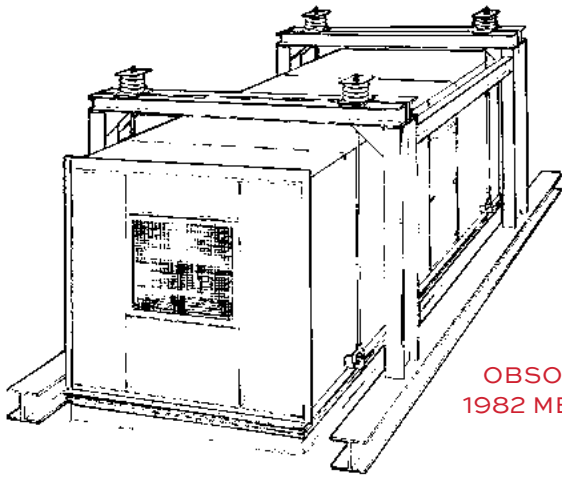

OBSOLETE 1982 METHOD

There were 3 or 4 very successful installations, but the method was too cumbersome and expensive. We found the only answer was to build a complete spring curb instead of just a cap on top of a standard curb. In our new complete curb, the springs are adjustable from the outside so they can be changed if need be and the base can be leveled. Our standard deflections are 3/4" (19mm), 1 1/2" (38mm) or 2 1/2" (64mm) and occasionally as much as 4 1/2" (114mm). They can be built to any height when access doors are needed, and configured to provide level unit support, regardless of the slope of the roof. We started working with this design in 1988, and have had great success. It is OSHPD approved for seismic zones. The following sketch gives you a broad idea of the construction. Please refer to the "Base" section of the catalog for specific bulletins.

SPECIFICATION N

Curb mounted rooftop equipment shall be mounted on spring isolation curbs. The lower member shall consist of a sheet metal Z section containing adjustable and removable steel springs that support the upper floating section. The upper frame must provide continuous support for the equipment and must be captive so as to resiliently resist wind forces. All directional neoprene snubber bushings shall be a minimum of 1/4" (6mm) thick. Steel springs shall be laterally stable and rest on 1/4" (6mm) thick neoprene acoustical pads. Hardware must be plated and the springs provided with a rust resistant finish. The curbs waterproofing shall consist of a continuous galvanized flexible counter flashing nailed over the lower curbs waterproofing and joined at the corners by EPDM bellows. All spring locations shall have access ports with removable waterproof covers. Lower curbs shall have provision for 2" (51mm) of insulation. Curb shall be Type RSC as manufactured by Mason Industries, Inc.

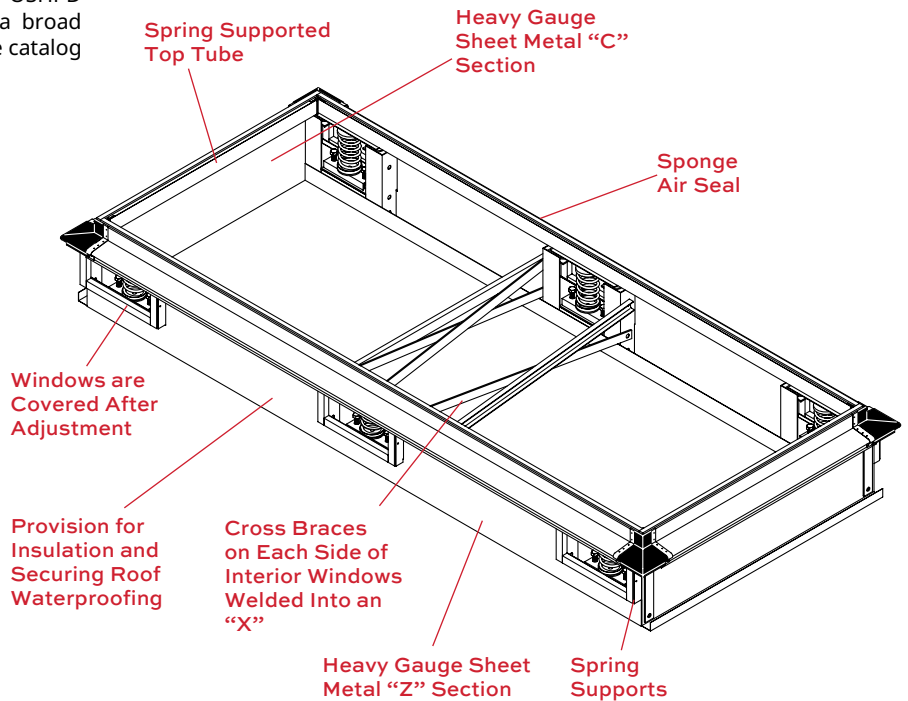
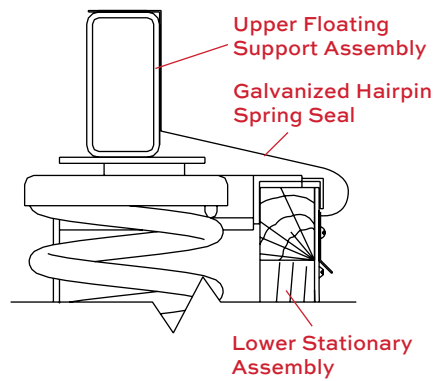

RSC COMPLETE ROOFTOP SPRING CURB

Explanation & Design Considerations

Flexible Rubber Connectors

SAFEFLEX

See *Bulletin Safeflex-1000* (page 9-9) for Complete Information.

An old sales technique is the flexing of a hand held rubber or metallic hose to show its flexibility. Nothing is limper than a rolled or folded canvas fire hose. However, when the hose is pressurized, it takes two men to bend and direct it. All flexible connectors are stiff under pressure, and you can only expect so much from them. They compensate for misalignment, relieve equipment flange strain, provide comparative freedom for floating equipment on isolators, and relieve the equipment of pipeline weight. Flexible connectors are a vital part of connections to equipment in seismic zones, as they will allow large equipment excursions without rupture.

Hose or rubber expansion joints reinforced with spiral wire or steel rings will not reduce pipeline vibration at RPM, but only at RPM multiplied by the number of blades in the pump wheel. Unfortunately, this frequency will continue to pulse through the fluid, and generally regenerate the pipeline vibration on the far side. In order to reduce noise and vibration at hydraulic frequency, a 2 arch molded rubber expansion joint is the correct choice as the reinforcement is much like the sidewall of an automobile tire. There is no steel wire and the expansion joint expands and contracts volumetrically at the hydraulic frequency. This dissipates energy and reduces the noise and vibration as confirmed by all of our acoustical tests. Spherical rubber connectors are preferable in general, as they are more effective high frequency vibration sound isolators and they do have the volumetric response capability not shared by metallic sections or wire reinforced hose.

Our rubber hose specification has been upgraded over the years. 38 years ago, we suggested rubber flanged hoses without qualification other than pressure and temperature capability. There were buckling problems and we found that this type of hose was manufactured with an allowable elongation of as much as 7% of its length (2" (51mm) longer for a 30" (750mm) section). We changed our specification to limit elongation to 1.25%. This was so costly we recommended installation of control cables to prevent excessive elongation. Unlike control rods, control cables are quite flexible transversely, and the assembly is manufactured with bridge bearing Neoprene bushings and 1/2" (13mm) thick neoprene washers of the proper area to limit loadings to a maximum of 1,000psi. Cables are a definite improvement over rigid control rods, but they still tend to reduce the effectiveness of any rubber connector as axial capabilities are limited. Fortunately, our rubber technology moved on. Modern spherical hand built molded rubber expansion joints are available for less than the cost of the ineffective rubber flanged hoses and far easier to install because of their short lengths.

We developed the method of pre-extending the expansion joints by leaving a gap that is longer than the nominal face to face dimension of the expansion joint to allow for the predicted fixed elongation at a given pressure. Since there is a need for maximum volumetric expansion to eliminate noise, we are recommending twin sphere molded expansion joints in all applications.

In the past 25 years, we have progressed from Neoprene to peroxide cured EPDM, because of greater temperature tolerance and resistance to ozone and sunlight. Nylon reinforcement moved on to Polyester and then to Kevlar. Nylon will fatigue and fail at temperatures between 200°F (93°C) and 250°F (121°C). We redesigned the mechanism for locking the raised face rubber flange behind the ductile iron flanges by building in a solid steel ring rather than the cable used by virtually all the other manufactures. With this combination of changed materials, we now had the safest and strongest rubber expansion joint on the market. However, there was still the possibility of manufacturing errors no matter how few. Therefore, all Safeflex connectors are factory tested to 150% of the rated pressure before shipment. (See Safeflex Development Bulletin SEJ-3 (page 9-3) in the Hose section.)

Test bulletins 901 and 902, show a 20db reduction in vibration acceleration in the pipelines. This reduction in pipeline wall vibration, as well as the smoothing of the fluid pulsation, lowered sound pressure levels in spaces far removed from the pumps, but adjacent to the piping by 10 to 20db.

These improvements peak at blade passage frequency where the vibratory and noise problems are usually most troublesome. Therefore, the specifications now include a requirement for a pre-tested product.

This is the only specification where we urge you not to accept competitive products unless they are manufactured with Kevlar reinforced high temperature peroxide cured EPDM, and embedded rings rather than cable in the rubber raised face flanges. We would not have developed Safeflex if the other construction were safe. We and all the other manufacturers had similar failures prior to our redesign. We have not had a failure since changing to the present Safeflex design.

Even so, all expansion joints should be installed on the equipment side of the shut off valves and only in equipment rooms. It is not recommended that they are installed out in the general structure in areas over finished ceilings, etc.

Specifications

SPECIFICATION O

Rubber expansion joints shall be peroxide cured EPDM throughout with Kevlar® tire cord reinforcement. Substitutions must have certifiable equal or superior characteristics. The raised face rubber flanges must encase solid steel rings to prevent pull out. Flexible cable wire is not acceptable. Sizes 1 1/2" through 24" (40 through 610mm) shall have a ductile iron external ring between the two spheres. Sizes 3/4" through 2" (20 through 50mm) may have one sphere, bolted threaded flange assemblies and cable retention.

Minimum standard ratings Sizes 1 1/2" through 16" (40 through 400mm), 250psi at 170°F and 215psi at 250°F. (1.72MPa at 77°C and 1.48MPa at 121°C); 18" through 24" (450 through 600mm) 180psi at 170°F and 155psi at 250°F. (1.24MPa at 77°C and 1.07 MPa at 121°C). Higher pressure ratings Sizes 1 1/2" through 16" (38 through 400mm), 335psi at 170°F and 285psi at 250°F. (2.31MPa at 77°C and 1.97MPa at 121°C), 18" through 24" (450 through 600mm) 225psi at 170°F and 190psi at 250°F. (1.55MPa at 77°C and 1.31 MPa at 121°C).

Safety factors shall be a minimum of 3/1. All expansion joints must be factory tested to 150% of maximum pressure for 4 minutes before shipment.

The piping gap shall be equal to the length of the expansion joint under pressure. Control rods passing through 1/2" (13mm) thick Neoprene washer bushings large enough to take the thrust at 1000psi (0.7 kg/mm²) of surface area may be used on unanchored piping as a noise break only. Submittals shall include two test reports by independent consultants showing minimum reductions of 20 DB in vibration accelerations and 10 DB in sound pressure levels at typical blade passage frequencies on this or a similar product by the same manufacturer. All expansion joints shall be installed on the equipment side of the shut off valves. Expansion joints shall be Type **SAFEFLEX SFDEJ**, **SFDCR** or **SFU** and Control Rods Type **CR** as manufactured by Mason Industries, Inc.

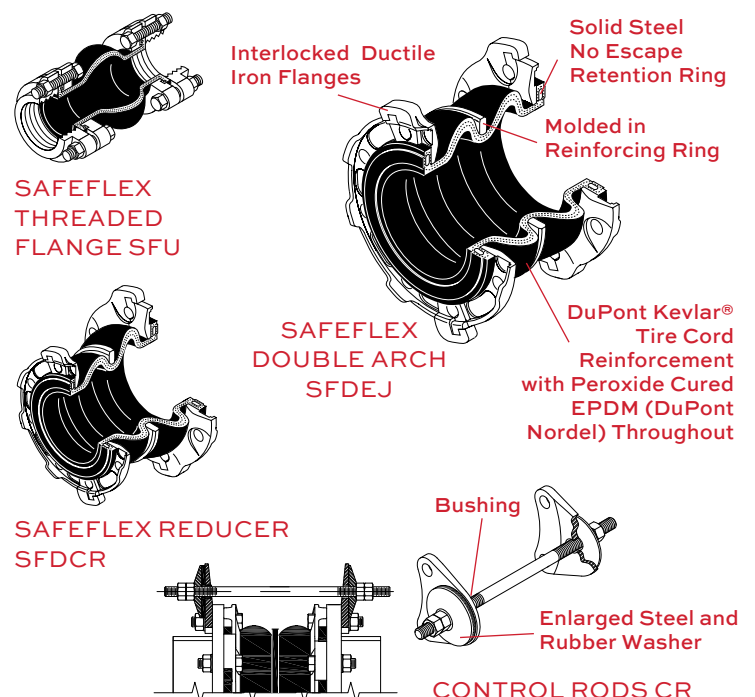

Flexible Metallic Hoses

TYPE BSS STAINLESS HOSES

See Bulletin BH-29 (page 10-7) for Complete Information.

Rubber connectors are preferable for sound and vibration attenuation, but careful consideration must be given to pressure and temperature and locations other than machine rooms. Stainless is recommended in locations away from equipment rooms and temperatures over 250°F (120°C) or pressures beyond published rubber pressure ratings.

Very short "Pump Connectors" got that way by chipping away at the 36" FF minimum used 50 years ago. These "getting the order" cost reductions continued, with no engineering reason, until no one dared go shorter. Field studies show they are useless, so we tested transverse hose stiffness for verification.

Bulletin BH-29 reviews these tests. The force required to displace various lengths of hose 1/8" (3mm) at different pressures is compared to the transverse stiffness of the connected piping. The hose stiffness should be lower, just as spring mounting stiffness must be lower than structural stiffness in isolation work. Unfortunately, even at 36" (914mm) FF we can only approach it in some sizes. We have no data on 48" (1219mm) lengths as they are impractical. We did no test work on copper as they are too light and flexible. As we learn more, we will keep you informed. Please refer to these tests as they are the basis of our recommended specifications.

The specification calls for a minimum number of corrugations per foot to reduce stiffness. Without this requirement and fewer corrugations, hoses are cheaper to manufacture, but poorer in performance. There may be hoses even more flexible, but ours are a good reference.

We are suggesting a floating flange at one end rather than two fixed flanges. This makes installation easier and eliminates the possibility of twisting the hose body during installation. Flanges are raised face to improve sealing pressure. We do not recommend weld ends as replacement is very costly in down time and field difficulty.

Reference Bulletin VH-30 (page 10-27) for Vee configurations to solve expansion and seismic movement problems.

SPECIFICATION P

Flexible stainless steel hoses with a safety factor of 4 shall be manufactured using Type 304 stainless steel braided hose with one fixed and one floating raised face carbon steel plate flange. Fittings must be 304 Stainless on Stainless lines. Sizes 2 1/2" (65mm) and smaller may have threaded nipples. Copper sweat ends, 4" (100mm) and smaller, may have SS (gas service) or Bronze (water service) bodies. Grooved ends may be used in sizes 2" through 12" (50 through 300mm). Welding is not acceptable. Minimum lengths, minimum live lengths and minimum number of convolutions per foot to assure flexibility are as tabulated. Shorter lengths are not acceptable.

Hoses shall be installed on the equipment side of the shut off valves horizontal and parallel to the equipment shafts wherever possible.

Submittals shall include original test data showing force/displacement, fittings, material, live lengths, number of corrugations per foot and safety factor at pressure ratings. Hoses shall be Type BSS or CPSB as manufactured by Mason Industries, Inc.

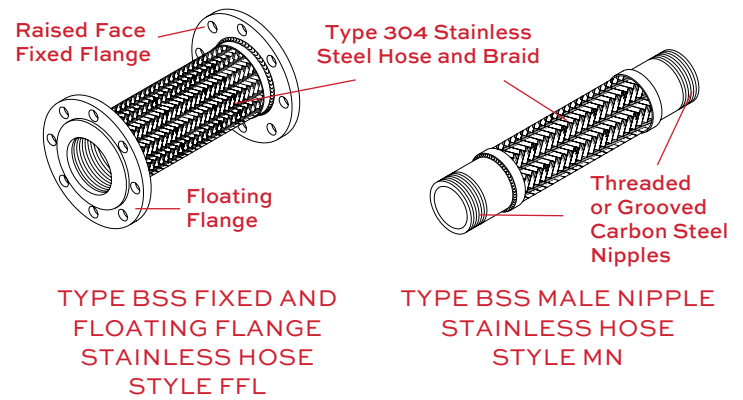

Pipe or Tubing Size (in) (mm)	Flanged				Threaded				Grooved Ends				Copper Sweat Bronze				Min. Convolutions per (ft) (m)	
	Face to Face (in) (mm)	Live Length (in) (mm)	End to End (in) (mm)	Live Length (in) (mm)	End to End (in) (mm)	Live Length (in) (mm)	End to End (in) (mm)	Live Length (in) (mm)	End to End (in) (mm)	Live Length (in) (mm)	End to End (in) (mm)	Live Length (in) (mm)						
1/2 15	—	—	—	—	24 610	193/4 502	—	—	—	—	18 457	141/4 362	92 302					
3/4 20	—	—	—	—	24 610	193/4 502	—	—	—	—	18 457	133/4 349	80 262					
1 25	—	—	—	—	24 610	193/4 502	—	—	—	—	18 457	133/8 340	72 236					
1 1/4 30	—	—	—	—	24 610	183/4 476	—	—	—	—	18 457	131/4 337	67 220					
1 1/2 40	24 610	217/8 556	24 610	183/4 476	—	—	—	—	18 457	13 330	63 207							
2 50	24 610	211/8 537	24 610	18 457	24 610	18 457	24 610	18 457	18 457	121/2 318	58 190							
2 1/2 65	24 610	211/8 537	24 610	17 432	24 610	17 432	24 610	18 457	18 457	103/4 273	48 157							
3 80	36 914	331/8 841	36 914	29 737	36 914	29 737	36 914	30 762	18 457	101/2 267	46 151							
4 100	36 914	331/8 841	36 914	29 737	36 914	29 737	36 914	28 711	24 610	151/2 394	32 105							
5 125	36 914	327/8 835	—	—	—	—	36 914	28 711	—	—	—	—	29 95					
6 150	36 914	327/8 835	—	—	—	—	36 914	28 711	—	—	—	—	25 82					
8 200	36 914	325/8 829	—	—	—	—	36 914	28 711	—	—	—	—	23 75					
10 250	36 914	325/8 829	—	—	—	—	36 914	26 660	—	—	—	—	21 69					
12 300	36 914	325/8 829	—	—	—	—	36 914	26 660	—	—	—	—	20 66					
14 350	36 914	325/8 829	—	—	—	—	—	—	—	—	—	—	18 59					
16 400	36 914	325/8 829	—	—	—	—	—	—	—	—	—	—	16 52					



Explanation & Design Considerations

Specifications

Wall, Floor And Ceiling Seals

SWS WALL SEAL

See Data Sheet DS-631 (page 4-53) for Complete Information.

The space around pipes passing through wall, floors and ceilings is often packed with fiberglass and caulked to prevent sound transmission. Efficiency is too dependent on field conditions and supervision.

We suggest a factory fabricated split seal clamped around the pipe with closed cell neoprene sponge as the filler. The seal is placed before the concrete pour or an opening is formed to be back packed later.

Fiberglass is used when temperatures exceed 225°F (107°C).

SPECIFICATION Q

Where pipes pass through structural openings, the space shall be sealed by a 2 piece clamp lined with 3/4" (19mm) thick Neoprene Sponge. Concrete or block shall be poured or built around the clamp or back packed with concrete. 10 lb density fiberglass with caulked ends will replace the sponge where temperatures exceed 225°F (107°C).

Seals shall be Type **SWS** as manufactured by Mason Industries, Inc.

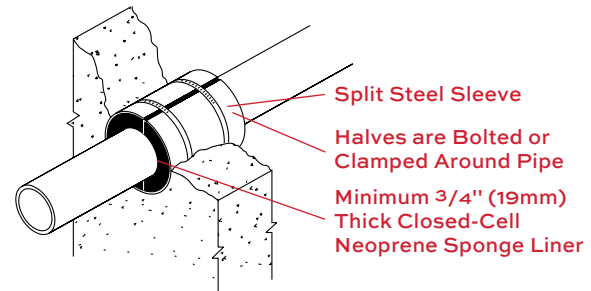

SWS WALL SEAL

Pipe Anchors

ADA PIPE ANCHORS

See Data Sheet DS-510 (page 7-36) for Complete Information.

In the 1982 publication, we used our all directional anchor for anchorage or anchoring the ends of oversized clamps that allowed piping to slide within the clamps. If the pipe was insulated, the clamps guided steel bars, welded to the pipe that protruded through the insulation. Those methods were a step forward. We continue anchoring but with welded gusseted brackets more commonly than clamps at heavy anchor points.

The use of oversized clamps and steel sliding on steel was less satisfactory as it tended to generate noise and insulating between the bars proved cumbersome. Therefore, we now use the ADA all directional anchors in anchor locations only and resilient sliding guides as described in Specification S to allow for expansion or contraction.

We have standardized on this one multi-purpose all directional anchor for simplicity of application and safety.

SPECIFICATION R

All-directional acoustical pipe anchors, consist of two sizes of steel tubing separated by a minimum 1/2" (13mm) thickness of 60 duro or softer neoprene. Vertical restraint shall be provided by similar material arranged to prevent up or down vertical travel. Allowable loads on the isolation material shall not exceed 500 psi (3.45 N/mm²) and the design shall be balanced for equal resistance in any direction. All-directional anchors shall be Type **ADA** as manufactured by Mason Industries, Inc.

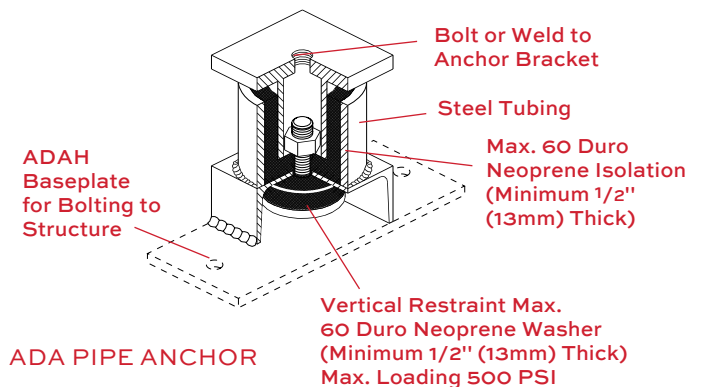

ADA PIPE ANCHOR

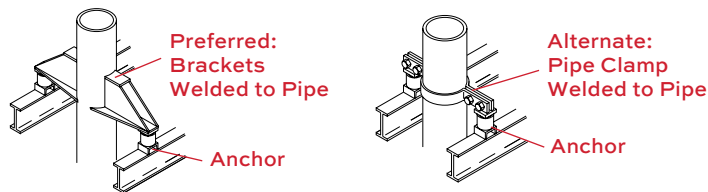

Riser Guides

VSG RISER GUIDES

See Data Sheet DS-510 (page 7-36) for Complete Information.

In 1982 we showed sliding guide locations using anchors under the ends of oversized pipe clamps around the pipe or steel guide bars welded to the pipe. This was difficult because of the need to weld the sliding bars to the pipe exterior and we found oversized clamps were not readily available. Perhaps the most discouraging part of the design was insulating between the guides and providing proper covering over the insulation. Therefore, we developed a new vertical sliding guide. This approach eliminates the sliding noise created by steel on steel within the clamp. Our literature shows the guides set for equal movements, but we can preset the guide to allow more movement upward or downward, as the case may be. If presetting does not solve the problem, the guide is manufactured with a longer body to accommodate the condition. The method is better because it utilizes standard diameter clamps and the insulation can be placed directly over the clamp with only the ends protruding to the guide. When piping is hot, the Neoprene in the guide is protected, as there is a sufficient temperature differential to the end of the clamp.

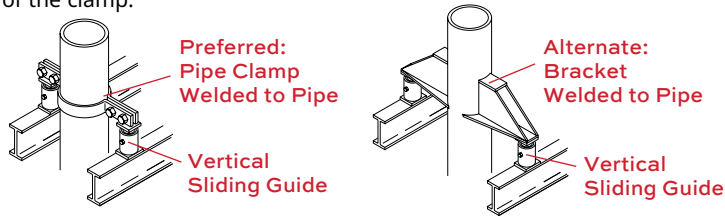

SPECIFICATION S

Pipe guides shall consist of a telescopic arrangement of two sizes of steel tubing separated by a minimum 1/2" (13mm) thickness of 60 durometer or softer neoprene. The height of the guides shall be preset with a set screw to allow vertical motion due to pipe expansion or contraction. Guides shall be capable of ±15/8" (41mm) motion, or to meet location requirements. Pipe guides shall be Type VSG as manufactured by Mason Industries, Inc.

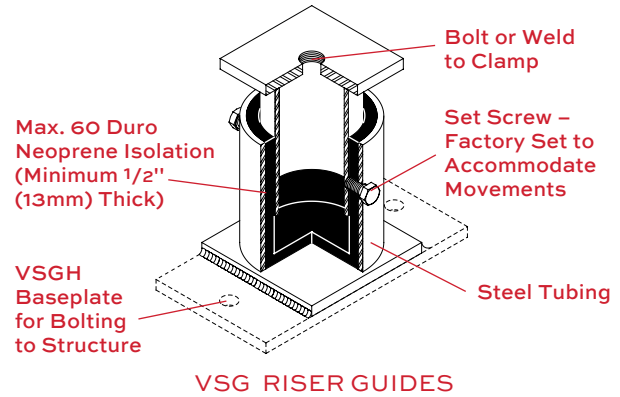

Horizontal Pipe Isolation

The hanger, mounting and anchor discussions on the previous pages include explanations of the various commodities and the reasons for their design. We have called for deflections in the first four supports to be equal to that of the equipment as these locations often require capacities that are as great as the equipment loadings and the frequencies and amplitudes are virtually the same as well. It would be completely inconsistent to reduce these deflections immediately. After four hangers or approximately 30 ft (9m) the reduction in amplitude makes it feasible to use a more economical hanger.

(NOTE: Earlier specifications said three hangers. To move 30 ft (9m) from equipment normally requires four as the first supports the riser.)

Some specifications limit the application of hangers to the "equipment room," "50 ft (15m) from equipment," etc., or some other formula based on a multiple of the diameter. They all try to reach out to a mythical location where the piping becomes "quiet". While it is usually true that the more severe vibration will occur close to the equipment, the rest of the pipeline is likely to remain troublesome. We have done expensive corrective work on pipe supports 20 stories away from the pumps and there is no way to predetermine if or where pipelines can be installed with solid supports and not risk noise transmission, because of pipe or building resonance. Therefore, we are continuing to suggest complete pipeline isolation as hangers are relatively inexpensive and worthwhile insurance. Rubber expansion joints minimize the noise problem at the source, but as explained in the Explanations of Specifications O and P, flex connectors do little or nothing to reduce vibration at RPM.

The specification calls for specific deflections for piping suspended from occupied spaces if the machine room is in the basement. The reason is the selection guide calls for minimum floor isolation in basements because there is normally nothing below them that is critical in any way or the basement may be on grade. If the hangers were to mimic these deflections, there would be a problem, because the piping may be suspended from ceilings under sensitive areas.

SPECIFICATION T

The first four pipe hangers in the main lines near the mechanical equipment shall be as described in Specification G. Hangers supporting piping 2" (50mm) and larger in all other locations throughout the building shall be isolated by hangers as described in Specification F. Floor supported piping shall rest on isolators as described in Specification D. Heat exchangers and expansion tanks are considered part of the piping run. The first four isolators from the isolated equipment shall have the same static deflection as specified for the mountings under the connected equipment. If piping is connected to equipment located in basements and hangs from ceilings under occupied spaces the first four hangers shall have 3/4" (19mm) deflection for pipe sizes up to and including 3" (80mm), 1 1/2" (40mm) deflection for pipe sizes over 3" (80mm) and up to and including 6" (150mm), and 2 1/2" (65mm) deflection thereafter. Where piping connects to mechanical equipment, install Specification O expansion joints or Specification P stainless hoses if O is not suitable for the service. All piping passing through the equipment walls, floors or ceilings shall be protected against sound leakage by means of an acoustical seal, as described in Specification Q.

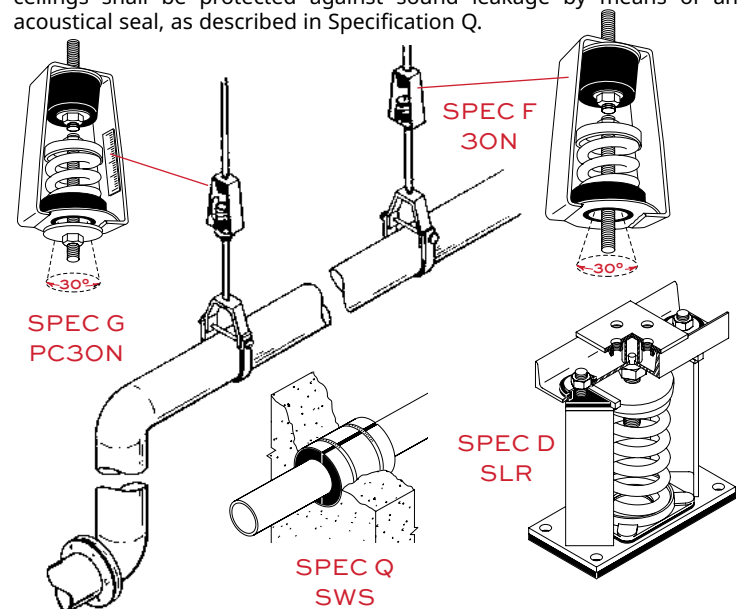

Explanation & Design Considerations

Specifications

Riser Isolation

See Bulletin Riser-112 (page 2-59) for Complete Information.

Riser isolation is simple in buildings up to 6 stories or so, since thermal expansion or contraction is a minor issue. It is often possible to solve the problem by providing a single basement support and guides at the midpoint and roofline. If thermal motion is larger, an isolator in the center of the structure will allow for half motions in both directions. The application is completed with a few resilient guides.

In high rise work, the situation is entirely different. We often work with massive risers where a single 20-story length is common. Single risers that run 40 stories or more are not that unusual. The thermal effects become very important and the risers become so heavy that it is necessary to distribute the weight on a number of floors. When the isolation is not critical, there is still the structural problem. Once an anchor is established, the supports must be able to follow the motion. As the pipe expands, it will lift off simple devices, such as pads and shift the load to the lowest or lower stories. Should the pipe contract, it will lift off pads in the lower sections and transfer the load to the top. Not allowing or considering this phenomena, has resulted in structural failure of the riser supports.

A riser may be resiliently supported in the basement or on a column that is bolted to a basement pier. Assuming branch-off connections are not a problem, and the horizontal run at the roof has allowed for expansion, when the system expands, there is no structural problem as none of the load rested on the intermediate floors to begin with. The same is true if the system contracts.

In another example, the pipe rises through a building where pipe clamps or brackets are used to transfer the load to successive floors. These attachments may or may not rest on isolation pads. When the system was installed at ambient temperature, all of the floors assumed part of the load. When the system is filled with water, there might be minor deflection in some of the floors to adjust to the slightly shorter or longer length, but this higher load is still evenly distributed.

However, if this is a hot water system with 2" (51mm) expansion, the top clamp would rise 2" (51mm) above structure. At the mid point 1" (25mm), at the quarter point 1/2" (13mm), etc. If there are no pads, the total load shifts to the lower 1 or 2 clamps immediately. If there are pads, the load shifts completely as soon as it exceeds the small initial deflection of the upper pads and this leads to the structural problem.

We are suggesting a safer system. Starting with the same parameters, it is always better to cut the motion at the two ends in half by establishing a neutral central resilient anchor. This anchor assumes no load. It is only there to direct the movement in the two directions.

Regardless of the length of the riser, there are an equal number of supports points, both above and below the anchor. An extreme design would be a support on every floor, but commonly they are on every third floor. These supports are selected with a minimum deflection of 3/4" (19mm), but four times the pipe travel at any given location. Since the ends are moving 1" (25mm) up at the top and 1" (25mm) down at the bottom, these mountings would have 4" (102mm) static deflection. Half way to the anchor, both top and bottom, the movement would be 1/2" (13mm) and the isolator deflection 2" (51mm). In this example, these four mountings would have enough capacity for the entire riser weight. That is why the neutral central anchor is not statically loaded.

When the expansion takes place, the top hanger would lose 25% of the 4" (102mm) deflection or 25% of its load and the mounting midway to the top would experience the same proportionate phenomena. The two mountings below the anchor point would be compressed an additional 25% each, so there is a load shift of minus 25% above and plus 25% below the anchor. Therefore the anchor location remains neutral. This load change of plus or minus 25% per support location is minor and causes no difficulty.

For a complete discussion, please refer to our Bulletin Riser-112 on page 2-59 of the catalog. The specification reflects this system.

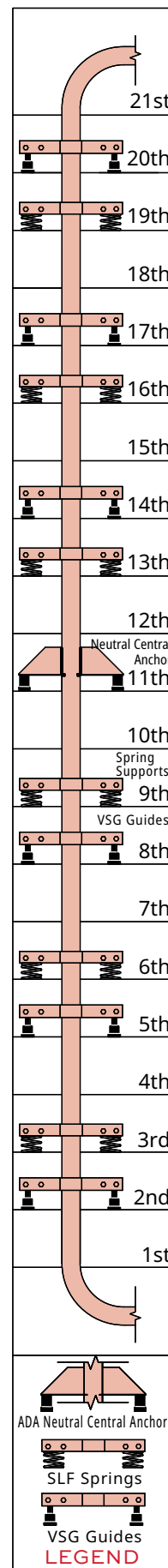

SPECIFICATION U

All vertical risers shall be supported by spring isolators designed to support the riser filled with water, if it is a water line. Assigned loads must be within the building design limits at the support points. Neutral central resilient anchors close to the center of the run shall direct movement up and down. The anchors shall be capable of holding an upward force equal to the water weight when the system is drained. If one level cannot accommodate this force, anchors can be located on 2 or 3 adjacent floors. Resilient guides shall be spaced and sized properly depending on the pipe diameter. Submittals must include the initial load, initial deflection, change in deflection, final load and change in load at all spring and anchor support locations, as well as guide spacing. The initial spring deflection shall be a minimum of 3/4" (19mm) or four times the thermal movement at the isolator location, whichever is greater. Calculations shall include pipe stress at end conditions and branch off locations and the manufacturer must include installation instructions. Submittal must be stamped and signed by a licensed professional engineer in the employ of the vibration vendor for at least 5 years. Proper provision shall be made for seismic protection in seismic zones. The isolator manufacturer shall be the same firm supplying the mechanical contract. Support spring mountings shall be Specification B, anchors Specification R, telescoping guides Specification S.

OPTIONAL ADDITION TO SPECIFICATION

The isolation vendor shall design and provide all brackets or clamps at riser spring guide and anchor locations. The contractor must install and adjust all isolators under the supervision of the isolator vendor or his representative.

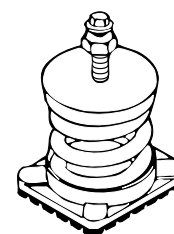

SPEC B
SLF

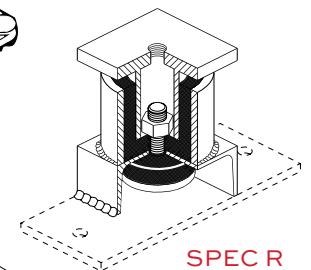

SPEC R
ADA

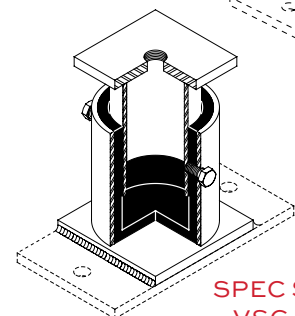

SPEC S
VSG

Duct Isolation

W30 HANGERS

DUCT ISOLATION

In general, duct hangers are limited to a 50 ft (15m) requirement from the fans as the vibration becomes minimal as the air flow smooths out. Deflections are limited to 3/4" (19mm) as these are light capacity supports, and we are isolating sheet metal resonance rather than the fan's primary disturbing frequency. We continue to be concerned if the duct work was designed for very high velocity, in which case the hangers are continued to the point where this velocity drops off.

SPECIFICATION V

All air ducts with a cross section of 2ft² (0.19m²) or larger shall be isolated from the building structure by Specification H hangers or B floor supports with a minimum deflection of 3/4" (19mm). Isolators shall continue for 50 ft (15m) from the equipment. If air velocity exceeds 1000 fpm (5.3mps), hangers or supports shall continue for an additional 50 ft (15m) or as shown on the drawings.

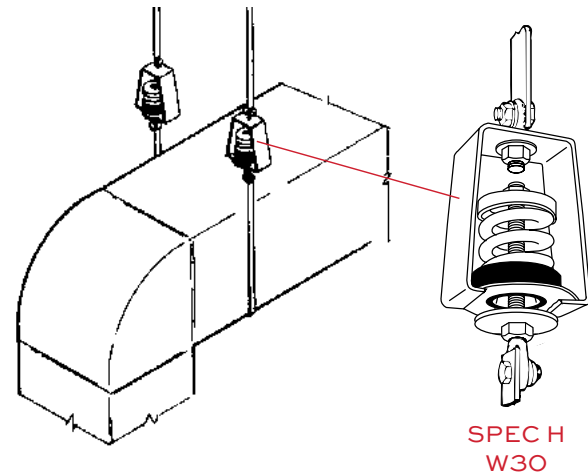

SPECIFICATION WRITING

All of the specification paragraphs are generic in their descriptions and there is never any need to change those descriptions as they apply to all installations. If you have accepted our explanations and like our wording, your specification would appear exactly as shown starting on page 2-26. The paragraph sections are in the format of the American Architectural Association. If this is not the format or the language you want to use, the specification paragraphs can be readily rearranged or edited. Once these paragraphs are in place, there is no need to change them from job to job or to omit or delete because the only isolators that are used are those that are called out on your equipment schedule. In our presentation, Schedule 4.01 is part of the specification and it appears on page 2-29. If you prefer keeping this schedule as part of your drawings, in 4.01 write "Equipment and Isolator schedule may be found in the drawings".

Schedule 4.01 is not really something you are adding. Most plans and specifications already have an equipment schedule. The change is just the addition of the two columns which are headed Vibration Isolation. On the left hand side, we have a specification paragraph letter or letters, and on the right, the static deflection. In most cases, the same isolator is recommended for a class of equipment in all locations. However, depending on the size of the equipment, the sensitivity of the structure and the occupancy of the building, a deflection must be selected by you to best fit the particular project.

The selection guide that follows provides this information. HVAC equipment is listed on the left. We reference the vibration isolator by the first letter in the columns under "Isolation and Deflection Criteria". The letters refer to the specification paragraphs. The second letter may reference the paragraph on base configuration. When there are three such letters, the first is always a vibration isolation device, the second the type of base, the third the type of flexible connector.

The next column over is the minimum isolator deflection in inches and millimeters. The two new columns on your schedule completely describe the isolation package for any machine listed in the schedule. There are the letter designations that refer to the specification paragraphs, and then the deflection that is to be used with the isolation device.

There are five choices across. Up at the top under "Isolation and Deflection Criteria" there is a description of where the machinery will be located in terms of a ground supported slab or basement or an upper floor with a given floor span. Most buildings have 30 ft (9m) floor spans, so most specifications are based on this deflection column. Should you have a 30 ft (9m) floor span, but it is a non-critical application, you might select from the 20 ft (6m) column. Vibration reduction will be somewhat poorer, but the cost lower. If the span is 30 ft (9m), but you are very concerned, you might make selections from the 40 ft (12m) column, because the additional isolator deflection provides a higher vibration isolation safety factor. In general, the column showing the actual floor span is very conservative to begin with and needs no further consideration.

The table on page 2-23 is typical of how you would show your selections. Whether you require no isolation because the equipment is in a remote equipment room away from the building or it is something like a fire pump and you are not concerned when it is in operation, you indicate no isolation by writing "None" in the chart. All the information in your schedule is taken from the isolator selection guide. When using this method, you have the opportunity to consider all of the equipment and there is little chance of leaving things out. On some jobs, you will not need to refer to all the isolators, but it is much easier to leave them in than editing the specification each time. The only isolators that are used are the ones that you include on your equipment schedule in the vibration isolation columns.

Below is a typical isolator schedule filled in.

4.01 Equipment Isolator Schedule

FAN SCHEDULE							Vibration Isolation Specification			
Fan No.	Location	Wheel Diam.		Arr.	Fan RPM	Motor HP		Isolator, Base, Restraint, Flexible Connector Specification Letters	Minimum Static Deflection	
		(in)	(mm)			(HP)	(kw)		(in)	(mm)
1	Penthouse	60	1525	1 SISW	503	30	22	B-L	1.50	38
2	3rd Floor	49	1245	3 SISW	720	25	19	B-L	0.75	19
3	Penthouse	73	1850	3 DIDW	405	75	56	B-L	3.50	89
4	Basement	36	915	2 SISW	930	15	11	A-J	0.35	9
5	3rd Floor	108	2745	3 SISW	400	125	94	B-L	2.50	64
6	3rd Floor	2-27	2-685	AC Unit*	533	10	7.5	F	0.75	19
7	Penthouse	3-12	3-305	AC Unit	630	5	4	B	0.75	19

*Suspended

PUMP SCHEDULE				Vibration Isolation and/or Seismic Restraints		
Pump No.	Location	Type	Motor HP (HP) (kw)	Specification Letters	Static Deflection (in) (mm)	
1	Penthouse	Split Casing	75 56	B-L-O	2.50	64
2	2nd Floor	Close Coupled	0.5 0.4	B-L-O	0.75	19
3	3rd Floor	End Suction	10 7.5	B-L-O	0.75	19
4	Basement	Close Coupled	3 2.0	A-O	0.35	9
5	Remote Basement	Split Casing	50 38	No Isolation		
6	2nd Floor	Fire Pump		No Isolation		

COMPRESSOR SCHEDULE				Vibration Isolation			
Compressor No.	Location	Type	Tonnage	Specification Letters	Static Deflection (in) (mm) (freq)		
1	Penthouse	500 Tons Centrifugal		D-O	1.50	38	-
2	Penthouse	750 Tons Screw Comp.		E-O	-	-	3 Hz

The information for the vibration isolation specification columns is found in the Specification Selection Guide pages 2-24 – 2-25. You need only reference the type of equipment and fill in the appropriate specification letters and deflections based on the floor span in the equipment's location.

In the given example, we are assuming that the floor spans are 30 ft (9m) at all locations. In your application, use the proper floor span tabulation.

You will note pump No. 5 has no isolation as it is in the basement under the garage, where any transmitted vibration would annoy no one. Fire pumps (No. 6) are seldom isolated.

In preparing your specification this way, you have an opportunity to consider every piece of equipment, and there is very little possibility of you overlooking something in the rush of getting a job completed.

**ISOLATION AND DEFLECTION CRITERIA FOR
4" (102mm) THRU 6" (152mm) THICK SOLID CONCRETE FLOORS (NOTE 6)**

SPECIFICATION SELECTION GUIDE To be used with Vibration Control Engineering Specifications for HVAC Equipment in Office Buildings, Colleges, Theaters and Similar Structures	Ground Supported Slab or Basement		20 ft (6m) Floor Span Possible Floor Defl. 0.67" (17mm)		30 ft (9m) Floor Span Possible Floor Defl. 1.0" (25mm)		40 ft (12m) Floor Span Possible Floor Defl. 1.33" (34mm)		50 ft (15m) Floor Span Possible Floor Defl. 1.67" (42mm)	
	Isolation Spec.	Isolation Deflection (in) (mm)	Isolation Spec.	Isolation Deflection (in) (mm)	Isolation Spec.	Isolation Deflection (in) (mm)	Isolation Spec.	Isolation Deflection (in) (mm)	Isolation Spec.	Isolation Deflection (in) (mm)
REFRIG. MACHINES										
Absorption Machines	A-O	0.35 9	D-O	0.75 19	D-O	0.75 19	D-O	1.5 38	D-O	1.5 38
Centrifugal Chillers or Heat Pumps										
Cooler Condenser Mounted Hermetic Compressors	A-O	0.35 9	D-O	0.75 19	D-O or E*-O	1.5 38 Max 3Hz	D-O or E*-O	1.5 38 Max 3Hz	D-K-O or E*-K-O	2.5 64 Max 3Hz
Cooler Condenser Alongside Hermetic Compressors	A-O	0.35 9	D-O	0.75 19	D-O or E*-O	1.5 38 Max 3Hz	D-O or E*-O	1.5 38 Max 3Hz	D-O or E*-O	2.5 64 Max 3Hz
Open Drive Type Compressors (note 3)	A-J-O	0.35 9	D-J-O	0.75 19	D-J-O or E*-J-O	1.5 38 Max 3Hz	D-J-O or E*-J-O	1.5 38 Max 3Hz	D-J-O or E*-J-O	2.5 64 Max 3Hz
Refrig. Reciprocating Compressors										
500 RPM to 750 RPM	B	0.75 19	B	1.5 38	B	1.5 38	B-K	2.5 64	B-K	3.5 89
751 RPM and Over	B	0.75 19	B	0.75 19	B or C*	1.5 38 Max 3Hz	B-K or C*-K	2.5 64 Max 3Hz	B-K or C*-K	3.5 89 Max 3Hz
Reciprocating Chillers or Heat Pumps										
500 RPM to 750 RPM	D-O	0.75 19	D-O	1.5 38	D-O	1.5 38	D-K-O	2.5 64	D-K-O	3.5 89
751 RPM and Over	D-O	0.75 19	D-O	0.75 19	D-O	1.5 38	D-K-O	2.5 64	D-K-O	3.5 89
PACKAGED STEAM GENERATIONS (Boilers)	A-P	0.35 9	D-P	0.75 19	D-P	0.75 19	D-P	1.5 38	D-P	2.5 64
PUMPS										
Close Coupled										
Thru 5hp (4kw)	A-L-O	0.35 9	B-L-O	0.75 19	B-L-O	0.75 19	B-L-O	1.5 38	B-L-O	1.5 38
7 1/2hp (5.6kw) and Larger	B-L-O	0.75 19	B-L-O	0.75 19	B-L-O	1.5 38	B-L-O	1.5 38	B-L-O	2.5 64
Base Mounted										
Thru 60hp (45kw)	B-L-O	0.75 19	B-L-O	0.75 19	B-L-O	1.5 38	B-L-O	1.5 38	B-L-O	2.5 64
75hp (56kw) and Larger	B-L-O	0.75 19	B-L-O	1.5 38	B-L-O or C*-L-O	2.5 64 Max 3Hz	B-L-O or C*-L-O	2.5 64 Max 3Hz	B-L-O or C*-L-O	3.5 89 Max 3Hz
FACTORY ASSEMBLED H & V UNITS										
Fan Coil Units (Unit Heaters)	F	0.75 19	F	0.75 19	F	0.75 19	F	0.75 19	F	0.75 19
Curb Mounted Roof Top Units	—	—	M	0.75 19	N	1.5 38	N	2.5 64	N	2.5 64
Suspended Units (for Fan Heads see Blowers Guide)										
Thru 5hp (4kw)	F	0.75 19	F	0.75 19	F	0.75 19	F	0.75 19	F	0.75 19
7 1/2hp (5.6kw) and Larger-275 RPM to 400 RPM	F	1.5 38	F	1.5 38	F	1.5 38	F	1.5 38	F	1.5 38
7 1/2hp (5.6kw) and Larger-401 RPM and Over	F	0.75 19	F	0.75 19	F	0.75 19	F	1.5 38	F	2.5 64
Floor Mounted Units (for Fan Heads see Blowers Guide)										
Thru 5hp (4kw)	A	0.35 9	B	0.75 19	B	0.75 19	B	0.75 19	B	0.75 19
7 1/2hp (5.6kw) and Larger-275 RPM to 400 RPM	A	0.35 9	B	1.5 38	B	1.5 38	B	1.5 38	B	1.5 38
7 1/2hp (5.6kw) to 40hp-401 RPM and Over	A	0.35 9	B	0.75 19	B	0.75 19	B	1.5 38	B-K	2.5 64
50hp (38kw) and Larger-401 RPM and Over	A	0.35 9	B	0.75 19	B	1.5 38	B-K	2.5 64	B-K	3.5 89

*NOTE: Isolators in **BOLD** are Air Springs recommended for highly critical locations.



SPECIFICATION SELECTION GUIDE To be used with Vibration Control Engineering Specifications for HVAC Equipment in Office Buildings, Colleges, Theaters and Similar Structures	Ground Supported Slab or Basement		20 ft (6m) Floor Span Possible Floor Defl. 0.67" (17mm)		30 ft (9m) Floor Span Possible Floor Defl. 1.0" (25mm)		40 ft (12m) Floor Span Possible Floor Defl. 1.33" (34mm)		50 ft (15m) Floor Span Possible Floor Defl. 1.67" (42mm)	
	Isolation & Seismic Spec.	Isolation Deflection (in) (mm)	Isolation & Seismic Spec.	Isolation Deflection (in) (mm)	Isolation & Seismic Spec.	Isolation Deflection (in) (mm)	Isolation & Seismic Spec.	Isolation Deflection (in) (mm)	Isolation & Seismic Spec.	Isolation Deflection (in) (mm)
AIR COMPRESSOR										
Tank Mounted Type	B-L-P	0.75 19	B-L-P	0.75 19	B-L-P	1.5 38	B-L-P	2.5 64	B-L-P	3.5 89
V - W Type	B-L-P	0.75 19	B-L-P	0.75 19	B-L-P	1.5 38	B-L-P	2.5 64	B-L-P	3.5 89
Horz, Vert, 1 or 2 Cylinders (note 4)										
275 RPM to 499 RPM	B-L [†] -P	2.5 64	B-L [†] -P	2.5 64	B-L [†] -P	2.5 64	B-L [†] -P	3.5 89	B-L [†] -P	3.5 89
500 RPM to 800 RPM	B-L [†] -P	1.5 38	B-L [†] -P	1.5 38	B-L [†] -P	2.5 64	B-L [†] -P	3.5 89	B-L [†] -P	3.5 89
[†] "L" Specification in this section only should read "L" type inertia bases with sufficient mass to limit motion to a theoretical double amplitude of 0.03" (.7mm)										

**ISOLATION AND DEFLECTION CRITERIA FOR
4" (102mm) THRU 6" (152mm) THICK SOLID CONCRETE FLOORS (NOTE 7)**

SPECIFICATION SELECTION GUIDE To be used with Vibration Control Engineering Specifications for HVAC Equipment in Office Buildings, Colleges, Theaters and Similar Structures	Ground Supported Slab or Basement		20 ft (6m) Floor Span Possible Floor Defl. 0.67" (17mm)		30 ft (9m) Floor Span Possible Floor Defl. 1.0" (25mm)		40 ft (12m) Floor Span Possible Floor Defl. 1.33" (34mm)		50 ft (15m) Floor Span Possible Floor Defl. 1.67" (42mm)		
	Isolation Spec.	Isolation Deflection (in) (mm)	Engineering Specifications and Minimum Static Deflection as tabulated below (note 1)								
BLOWERS											
Utility Sets											
Floor Mounted (note 5)	A	0.35 9	Spec B for 0.75" (19mm) to 1.5" (38mm) deflection and Spec B-L for over 1.5" (38mm) deflection with deflection from ^Blower Minimum Deflection Guide, but not to exceed 2.5" (64mm).								
Roof Mounted	—	— —	Spec B-L with deflection from ^Blower Minimum Deflection Guide. If roof will not handle concrete base load use Spec D for 0.75" (19mm) and 1.5" (38mm) deflection and Spec D-K for over 1.5" (38mm) deflection.								
Suspended Unit (note 5)	—	— —	Spec F with deflection from ^Blower Minimum Deflection Guide, not to exceed 2.5" (64mm) deflection.								
Centrifugal Blowers (note 6)	A-L	0.35 9	Spec B-L with deflection from ^Blower Minimum Deflection Guide.								
Fan Heads (HVAC Unit Blower Section Only)											
Floor Mounted	A-I	0.35 9	Spec B-I if 0.75" (19mm) to 1.5" (38mm) deflection or Spec B-K-I for deflection over 2.5" (64mm) to 4.5" (114mm) from ^Blower Minimum Deflection Guide.								
Suspended Units			Spec F-I with deflection from ^Blower Minimum Deflection Guide.								
Tubular Centrifugal and Axial Fans											
Suspended Units			Spec F with deflection from ^Blower Minimum Deflection Guide, Spec F-I for over 4" (102mm) static pressure.								
Floor Mounted with Motor on/in Fan Casing	A	0.35 9	Spec B for 0.75" (19mm) to 1.5" (38mm) deflection and Spec B-K-I for over 2.5" (64mm) to 4.5" (114mm) deflection with deflection from ^Blower Minimum Deflection Guide, Spec B-L-I or B-I for over 4" (102mm) static pressure.								
Floor Mounted Arrangement 1 or any Separately Mounted Motor	A-L	0.35 9	Spec B-L with deflection from ^Blower Minimum Deflection Guide.								
COOLING TOWERS & CONDENSING UNITS	A	0.35 9	Spec D or E* with deflection from ^Blower Minimum Deflection Guide.								

*NOTE: Isolators in **BOLD** are Air Springs recommended for highly critical locations.

^Blower Minimum Deflection Guide is on the next page.



BLOWER MINIMUM DEFLECTION GUIDE

When blowers are 60 HP (45kw) or larger, select deflection requirements for next larger span. A minimum of 2.5" (64mm)

should be used unless larger deflections are called for on the chart or these fans are located in the lowest sub-basement or on a slab on grade.

Fan Speed RPM	Required Deflection for Ground Supported Slab or Basement		Required Deflection for 20 ft (6m) Floor Span		Required Deflection for 30 ft (9m) Floor Span		Required Deflection for 40 ft (12m) Floor Span		Required Deflection for 50 ft (15m) Floor Span	
	(in)	(mm)	(in)	(mm)	(in)	(mm)	(in)	(mm)	(in)	(mm)
500 and up	0.35	9	0.75	19	1.5	38	2.5	64	3.5	89
375 - 499	0.35	9	1.5	38	2.5	64	3.5	89	3.5	89
300 - 374	0.35	9	2.5	64	2.5	64	3.5	89	3.5	89
225 - 299	0.35	9	3.5	89	3.5	89	3.5	89	3.5	89
175 - 224	0.35	9	3.5	89	4.5	114	4.5	114	4.5	114

GUIDE NOTES

1. Minimum deflection called for in this specification are not 'nominal' but certifiable minimums. The 0.75" (19mm), 1.5" (38mm), 2.5" (64mm), 3.5" (89mm), and 4.5" (114mm) minimums should be selected from manufacturer's nominal 1" (25mm), 2" (51mm), 3" (76mm), 4" (102mm) and 5" (127mm) series respectively. Air spring isolation Specifications C & E may be substituted for steel springs above in highly sensitive noise free locations.
2. Vacuum, Condensate or Boiler Feed Pumps shall be mounted with their tanks on a common Specification L base with deflections as specified for base mounted pumps.
3. The base described in Specification J is used under the drive side only. Individual mountings as described in Specification A, D or E are used under the Cooler and Condenser.
4. This type of compressor is highly unbalanced and sometimes requires inertia bases weighing 5 to 7 times equipment weight to reduce running motion.
5. Limit deflection for utility sets 18" (457mm) wheel diameter and smaller to 1 1/2" (38mm).

6. FLOATING CONCRETE INERTIA BASES (Specification L).
Floating concrete inertia bases do not reduce vibration transmitted to the structure through the mountings. These bases will reduce vibratory motion, provide a very rigid machine base and minimize spring reactions to fan thrust. Engineers preferring steel bases rather than the concrete mentioned above in Specification B-L should change the designation to B-J. Concrete is preferred for all fans operating at static pressure above 4" (102mm) and on roof tops.
7. LIGHT FLOOR CONSTRUCTION
When floors or roofs are lighter than 4" (102mm) solid concrete, it is desirable to introduce a localized mass under the vibration mountings in the form of a sub-base. This sub-base should be 12" (305mm) thick and 12" (305mm) longer and wider than the mechanical equipment above it. When this mass is provided the 30 ft (9m) minimum static deflection requirements will suffice even in longer bays. The mass is also useful for unusually large bays over 50 ft (15m). When floors are lighter than the 4" (102mm) concrete or the location is in a particularly sensitive area and the mass described above cannot be introduced, select deflection requirements for the next larger span.

The following is the complete VCS SPECIFICATION, combining the individual specifications from pages 2-9 - 2-22. We hope you find this format helpful.

Complete Specification

PART 1 - GENERAL

1.01 Scope

A. Intent

1. All mechanical equipment, piping and ductwork as noted on the equipment schedule or in the specification shall be mounted on or suspended from vibration isolators to reduce the transmission of vibration and mechanically transmitted sound to the building structure. Vibration isolators shall be selected in accordance with the weight distribution so as to produce reasonably uniform deflections.
2. All isolation materials shall be supplied by the same manufacturer.
3. Any variance or non-compliance with these specification requirements shall be corrected by the contractor in an approved manner.

B. The work in this section includes, but is not limited to the following:

1. Vibration isolation for piping, ductwork and equipment.
2. Equipment isolation bases.
3. Flexible piping connections.
4. Resilient Pipe Anchors and Guides.

1.02 Submittal Data Requirements

A. The manufacturer of vibration isolation shall provide submittals for products as follows:

1. Descriptive Data:

- a. Schedules of flexibly mounted equipment, referencing drawings by number.

- b. Catalog cuts or data sheets on vibration isolators.

2. Drawings:

- a. Submit details of equipment bases including dimensions, structural member sizes and support point locations.
- b. Submit details of isolation hangers for ceiling hung equipment, piping and ductwork.
- c. Submit details of mountings for floor-supported equipment, piping and ductwork.
- d. All hanger, mounting or pad drawings shall indicate deflections and model numbers as well as any other requirements in the specifications.
- e. Spring diameters, rated loads and deflections, heights at rated load and closed height shall be provided for all springs shown in the submittals in tabular form.
- f. Complete flexible connector details.

PART 2 - PRODUCTS

2.01 Intent

- A.** All vibration isolators described in this section shall be the product of a single manufacturer. Mason Industry's products are the basis of these specifications; products of other manufacturers will be considered provided samples strictly comply with the specification and have the approval of the specifying engineer. Submittals and certification sheets shall be in accordance with section 1.02.



2.02 Product Description

SPECIFICATION

- A. Neoprene mountings shall have a minimum static deflection of 0.35" (9mm). All metal surfaces shall be neoprene covered and have friction pads both top and bottom. Bolt holes shall be provided on the bottom and a tapped hole and cap screw on top. Steel rails shall be used above the mountings under equipment such as small vent sets to compensate for the overhang. Mountings shall be Type **ND** or rails Type **RND** as manufactured by Mason Industries, Inc.
- B. Spring isolators shall be freestanding and laterally stable without any housing and complete with a molded neoprene cup or 1/4" (6mm) neoprene acoustical friction pad between the baseplate and the support. All mountings shall have leveling bolts that must be rigidly bolted to the equipment. Installed and operating heights shall be equal. The ratio of the spring diameter divided by the compressed spring height shall be no less than 0.8. Springs shall have a minimum additional travel to solid equal to 50% of the rated deflection. Submittals shall include spring diameters, deflection, compressed spring height and solid spring height. Mountings shall be Type **SLF**, as manufactured by Mason Industries, Inc.
- C. Multiple bellow air springs shall be manufactured with powder-coated upper and lower steel sections connected by a replaceable, flexible Nylon-reinforced Neoprene element to achieve a maximum natural frequency of 3 Hz. (We have found 3 Hz adequate when using air springs. Should the specifying engineer require a lower frequency, change the 3 Hz to the lower number). Burst pressure must be a minimum of 3 times the published maximum operating pressure. All air spring systems shall be equipped with 3 leveling valves connected to the building control air or a supplementary air supply to maintain elevation plus or minus 1/8" (3mm). An air filter and water separator shall be installed before the air distribution system to the leveling valves.
- Submittals shall include natural frequency, as well as load and damping tests, all as performed by an independent lab or acoustician. Air springs shall be Type **MT** and leveling valves Type **LV** as manufactured by Mason Industries, Inc.
- D. Equipment with large variations in the operating and installed weight, such as chillers, boilers, etc., and equipment exposed to the wind such as cooling towers, roof mounted fans and roof mounted air handling equipment shall be mounted on spring mountings, as described in Engineering Specification B, including the neoprene acoustical pad within a rigid housing that includes vertical limit stops to prevent spring extension when weight is removed and temporary steel spacers between the upper and lower housings. Housings shall serve as blocking during erection. When the equipment is at full operating weight, the springs shall be adjusted to assume the weight and the spacers removed, without changing the installed and operating heights. All restraining bolts shall have large rubber grommets to provide cushioning in the vertical as well as horizontal modes. The hole through the bushing shall be a minimum of 3/4" (19mm) larger in diameter than the restraining bolt. Horizontal clearance on the sides between the spring assembly and the housing shall be a minimum of 1/2" (13mm) to avoid bumping and interfering with the spring action. Vertical limit stops shall be out of contact during normal operation. Cooling tower mounts are to be located between the supporting steel and the roof or the grillage and dunnage as shown on the drawings when there is no provision for direct mounting. Housings and springs shall be powder coated and hardware electro-galvanized. Mountings shall be Type **SLR** or **SLRSO** as manufactured by Mason Industries, Inc.
- E. Equipment with large variations in the operating and installed weight, such as chillers, boilers, etc., and equipment exposed to the wind such as cooling towers, roof mounted fans and roof mounted air handling equipment shall be mounted on air springs, as described in Engineering Specification C, but within a rigid housing that includes vertical limit stops to prevent spring extension when weight is removed and temporary steel spacers between the upper and lower housings. Housings shall serve as blocking during erection. When the equipment is at full operating weight, the air springs shall be pressurized to take the weight so the spacers can be removed without changing the installed and operating heights. All restraining bolts shall have large rubber grommets to provide cushioning in the vertical as well as the horizontal modes. The hole through the bushing shall be a minimum of 3/4" (19mm) larger in diameter than the restraining bolt. Horizontal clearance between the air spring assembly and the housing shall be a minimum of 1/2" (13mm) to avoid bumping and interference with the spring action. Vertical limit stops shall be out of contact during normal operation. Mountings and air spring parts shall be powder coated. Hardware electro-galvanized. Air spring systems shall be connected to the building control air or a supplementary air supply and equipped with three leveling valves to maintain level within plus or minus 1/8" (3mm). Cooling tower mounts are to be located between the supporting steel and the roof or the grillage and dunnage as shown on the drawings when there is no provision for direct mounting. Mountings shall be Type **SLR-MT** and leveling valves Type **LV** as manufactured by Mason Industries, Inc.
- F. Hangers shall consist of rigid steel frame containing a minimum 1 1/4" (32mm) thick LDS rubber element at the top and a steel spring with general characteristics as in Specification B seated in a steel washer reinforced LDS rubber cup on the bottom. The LDS rubber element and the cup shall have molded bushings projecting through the steel box. In order to maintain stability the boxes shall not be articulated as clevis hangers nor the LDS rubber element stacked on top of the spring. Spring and hanger lower hole diameters shall be large enough to permit the hanger rod to swing through a 30° arc from side to side before contacting the cup bushing and short circuiting the spring. Submittals shall include a hanger drawing showing the 30° capability. Hangers shall be Type **30N** as manufactured by Mason Industries, Inc.
- G. Hangers shall be as described in F, but they shall be precompressed and locked at the rated deflection by means of a steel precompression washer to keep the piping or equipment at a fixed elevation during installation. The hangers shall be designed with a release mechanism to free the spring after the installation is complete and the hanger is subjected to its full load. Deflection shall be clearly indicated by means of a scale. Submittals shall include a drawing of the hanger showing the 30° capability. Hangers shall be Type **PC30N** as manufactured by Mason Industries, Inc.
- H. Hangers shall be manufactured with minimum characteristics as in Specification B, but without the LDS Rubber element. Springs are seated in a steel washer reinforced LDS Rubber cup molded with a rubber bushing projecting through the bottom hole to prevent rod to hanger contact. Spring diameters and the lower hole sizes, shall be large enough to allow the hanger rod to swing through a 30° arc from side to side before contacting the cup bushing.
- If ducts are suspended by flat strap iron, the hanger assembly shall be modified by the manufacturer with an eye on top of the box and on the bottom of the spring hanger rod to allow for bolting to the hanger straps. Submittals on either of the above hangers shall include a scale drawing of the hanger showing the 30° capability. Hangers for rods shall be Type **30** or for straps Type **W30** as manufactured by Mason Industries, Inc.
- I. When total air thrust exceeds 10% of the isolated weight, floor mounted or suspended air handling equipment shall be protected against excessive displacement by the use of horizontal thrust restraints. The restraint shall consist of a modified Specification B spring mounting. Restraint springs shall have the same deflection as the isolator springs. The assembly shall be preset at the factory and fine tuned in the field to allow for a maximum of 1/4" (6mm) movement from stop to maximum thrust. The assemblies shall be furnished with rod and angle brackets for attachment to both the equipment and duct work or the equipment and the structure. Restraints shall be attached at the center line of thrust and symmetrically on both sides of the unit. Horizontal thrust restraints shall be Type **WB** as manufactured by Mason Industries, Inc.
- J. Vibration isolation manufacturer shall furnish integral structural steel bases. Rectangular bases are preferred for all equipment. Centrifugal refrigeration machines and pump bases may be T- or L- shaped. Pump bases for split case pumps shall be large enough to support suction and discharge elbows. All perimeter members shall be steel beams with a minimum depth equal to 1/10 of the longest dimension of the base. Base depth need not exceed 14" (356mm) provided that the deflection and misalignment is kept within acceptable limits as determined by the manufacturer. Height saving brackets shall be employed in all mounting locations to provide a base clearance of 1" (25mm). Bases shall be Type **WF** as manufactured by Mason Industries, Inc.

- K. Vibration isolation manufacturer shall provide steel members welded to height saving brackets to cradle equipment having legs or bases that do not require a complete supplementary base. Members shall have sufficient rigidity to prevent distortion of equipment. Inverted saddles shall be Type **ICS**, as manufactured by Mason Industries, Inc.
- L. Vibration isolation manufacturer shall furnish rectangular steel concrete pouring forms for floating concrete bases. Bases for split case pumps shall be large enough to provide support for suction and discharge elbows. Bases shall be a minimum of 1/12 of the longest dimension of the base but not less than 6" (152mm). The base depth need not exceed 12" (305mm) unless specifically recommended by the base manufacturer for mass or rigidity. Forms shall include minimum concrete reinforcing consisting of 1/2" (13mm) bars welded in place on 6" (152mm) centers running both ways in a layer 1 1/2" (38mm) above the bottom. Forms shall be furnished with steel templates to hold the anchor bolt sleeves and anchor bolts while concrete is being poured. Height saving brackets shall be employed in all mounting locations to maintain a 1" (25mm) clearance below the base. Wooden formed bases leaving a concrete rather than a steel finish are not acceptable. Base shall be Type **BMK** or **K** as manufactured by Mason Industries, Inc.
- M. Curb mounted rooftop equipment shall be mounted on vibration isolation bases that fit over the roof curb and under the isolated equipment. The extruded aluminum top member shall overlap the bottom to provide water runoff independent of the seal. Aluminum members shall house electro-galvanized or powder coated springs selected for 3/4" (19mm) minimum deflection. Travel to solid shall be 1 1/2" (38mm) minimum. Spring diameters shall be no less than 0.8 of the spring height at rated load. Wind resistance shall be provided by means of resilient snubbers in the corners with a minimum clearance of 1/4" (6mm) so as not to interfere with the spring action except in high winds. Manufacturer's self adhering closed cell sponge gasketing must be used both above and below the base and a flexible EPDM duct like connection shall seal the outside perimeter. Foam or other sliding or shear seals are unacceptable in lieu of the EPDM duct like closure. Submittals shall include spring deflections, spring diameters, compressed spring height and solid spring height as well as seal and wind resistance details. Curb mounted bases shall be Type **CMAB** as manufactured by Mason Industries, Inc.
- N. Curb mounted rooftop equipment shall be mounted on spring isolation curbs. The lower member shall consist of a sheet metal Z section containing adjustable and removable steel springs that support the upper floating section. The upper frame must provide continuous support for the equipment and must be captive so as to resiliently resist wind forces. All directional neoprene snubber bushings shall be a minimum of 1/4" (6mm) thick. Steel springs shall be laterally stable and rest on 1/4" (6mm) thick neoprene acoustical pads. Hardware must be plated and the springs provided with a rust resistant finish. The curbs waterproofing shall consist of a continuous galvanized flexible counter flashing nailed over the lower curbs waterproofing and joined at the corners by EPDM bellows. All spring locations shall have access ports with removable waterproof covers.

Lower curbs shall have provision for 2" (51mm) of insulation. Curb shall be Type **RSC** as manufactured by Mason Industries, Inc.

- O. Rubber expansion joints shall be peroxide cured EPDM throughout with Kevlar® tire cord reinforcement. Substitutions must have certifiable equal or superior characteristics. The raised face rubber flanges must encase solid steel rings to prevent pull out. Flexible cable wire is not acceptable. Sizes 1 1/2" through 24" (40 through 610mm) shall have a ductile iron external ring between the two spheres. Sizes 3/4" through 2" (20 through 50mm) may have one sphere, bolted threaded flange assemblies and cable retention.

Minimum standard ratings Sizes 1 1/2" through 16" (40mm through 400mm), 250psi at 170°F and 215psi at 250°F. (1.72MPa at 77°C and 1.48MPa at 121°C); 18" through 24" (450 through 600mm) 180psi at 170°F and 155psi at 250°F. (1.24MPa at 77°C and 1.07 MPa at 121°C). Higher pressure ratings Sizes 1 1/2" through 16" (40 through 400mm), 335psi at 170°F and 285psi at 250°F. (2.31MPa at 77°C and 1.97MPa at 121°C), 18" through 24" (450 through 600mm) 225psi at 170°F and 190psi at 250°F. (1.55MPa at 77°C and 1.31 MPa at 121°C).

Safety factors shall be a minimum of 3/1. All expansion joints must be factory tested to 150% of maximum pressure for 4 minutes before shipment.

The piping gap shall be equal to the length of the expansion joint under pressure. Control rods passing through 1/2" (13mm) thick neoprene washer bushings large enough to take the thrust at 1000psi (0.7 kg/mm²) of surface area may be used on unanchored piping as a noise break only. Submittals shall include two test reports by independent consultants showing minimum reductions of 20 DB in vibration accelerations and 10 DB in sound pressure levels at typical blade passage frequencies on this or a similar product by the same manufacturer. All expansion joints shall be installed on the equipment side of the shut-off valves. Expansion joints shall be Type **SAFFLEX SFDEJ**, **SFDCR** or **SFU** and Control Rods Type **CR** as Type manufactured by Mason Industries, Inc.

- P. Flexible stainless steel hoses with a safety factor of 4 shall be manufactured using Type 304 stainless steel braided hose with one fixed and one floating raised face carbon steel plate flange. Fittings must be 304 Stainless on Stainless lines. Sizes 2 1/2" (65mm) and smaller may have threaded nipples. Copper sweat ends, 4" (100mm) and smaller, may have SS (gas service) or Bronze (water service) bodies. Grooved ends may be used in sizes 2" through 12" (50 through 300mm). Welding is not acceptable. Minimum lengths, minimum live lengths and minimum number of convolutions per foot to assure flexibility are as tabulated. Shorter lengths are not acceptable.

Hoses shall be installed on the equipment side of the shut-off valves horizontal and parallel to the equipment shafts wherever possible.

Submittals shall include original test data showing force/displacement, fittings, material, live lengths, number of corrugations per foot and safety factor at pressure ratings. Hoses shall be Type **BSS** or **CPSB** as manufactured by Mason Industries, Inc.

Pipe or Tubing Size (in) (mm)	Flanged				Threaded				Grooved Ends				Copper Sweat Bronze				Min. Convolutions per (ft) (m)	
	Face to Face (in) (mm)	Live Length (in) (mm)	End to End (in) (mm)	Live Length (in) (mm)	End to End (in) (mm)	Live Length (in) (mm)	End to End (in) (mm)	Live Length (in) (mm)	End to End (in) (mm)	Live Length (in) (mm)	End to End (in) (mm)	Live Length (in) (mm)						
1/2 15	—	—	—	—	24	610	193/4	502	—	—	—	—	18	457	141/4	362	92	302
3/4 20	—	—	—	—	24	610	193/4	502	—	—	—	—	18	457	133/4	349	80	262
1 25	—	—	—	—	24	610	193/4	502	—	—	—	—	18	457	133/8	340	72	236
1 1/4 30	—	—	—	—	24	610	183/4	476	—	—	—	—	18	457	131/4	337	67	220
1 1/2 40	24	610	217/8	556	24	610	183/4	476	—	—	—	—	18	457	13	330	63	207
2 50	24	610	211/8	537	24	610	18	457	24	610	18	457	18	457	121/2	318	58	190
2 1/2 65	24	610	211/8	537	24	610	17	432	24	610	18	457	18	457	103/4	273	48	157
3 80	36	914	331/8	841	36	914	29	737	36	914	30	762	18	457	101/2	267	46	151
4 100	36	914	331/8	841	36	914	29	737	36	914	28	711	24	610	151/2	394	32	105
5 125	36	914	327/8	835	—	—	—	—	36	914	28	711	—	—	—	—	29	95
6 150	36	914	327/8	835	—	—	—	—	36	914	28	711	—	—	—	—	25	82
8 200	36	914	325/8	829	—	—	—	—	36	914	28	711	—	—	—	—	23	75
10 250	36	914	325/8	829	—	—	—	—	36	914	26	660	—	—	—	—	21	69
12 300	36	914	325/8	829	—	—	—	—	36	914	26	660	—	—	—	—	20	66
14 350	36	914	325/8	829	—	—	—	—	—	—	—	—	—	—	—	—	18	59
16 400	36	914	325/8	829	—	—	—	—	—	—	—	—	—	—	—	—	16	52



Q. Where pipes pass through structural openings, the space shall be sealed by a 2 piece clamp lined with 3/4" (19mm) thick Neoprene Sponge. Concrete or block shall be poured or built around the clamp or back packed with concrete. 10 lb density fiberglass with caulked ends will replace the sponge where temperatures exceed 225°F (107°C).

Seals shall be Type **SWS** as manufactured by Mason Industries, Inc.

R. All-directional acoustical pipe anchors, consist of two sizes of steel tubing separated by a minimum 1/2" (13mm) thickness of 60 duro or softer LDS Rubber. Vertical restraint shall be provided by similar material arranged to prevent up or down vertical travel. Allowable loads on the isolation material shall not exceed 500 psi (3.45 N/mm²) and the design shall be balanced for equal resistance in any direction. All-directional anchors shall be Type **ADA** as manufactured by Mason Industries, Inc.

S. Pipe guides shall consist of a telescopic arrangement of two sizes of steel tubing separated by a minimum 1/2" (13mm) thickness of 60 durometer or softer neoprene. The height of the guides shall be preset with a set screw to allow vertical motion due to pipe expansion or contraction. Guides shall be capable of ±15/8" (41mm) motion, or to meet location requirements. Pipe guides shall be Type **VSG** as manufactured by Mason Industries, Inc.

T. The first four pipe hangers in the main lines near the mechanical equipment shall be as described in Specification G. Hangers supporting piping 2" (50mm) and larger in all other locations throughout the building shall be isolated by hangers as described in Specification F. Floor supported piping shall rest on isolators as described in Specification D. Heat exchangers and expansion tanks are considered part of the piping run. The first four isolators from the isolated equipment shall have the same static deflection as specified for the mountings under the connected equipment. If piping is connected to equipment located in basements and hangs from ceilings under occupied spaces the first four hangers shall have 3/4" (19mm) deflection for pipe sizes up to and including 3" (75mm), 1 1/2" (40mm) deflection for pipe sizes over 3" (75mm) and up to and including 6" (150mm), and 2 1/2" (65mm) deflection thereafter. Where piping connects to mechanical equipment, install Specification O expansion joints or Specification P stainless hoses if O is not suitable for the service. All piping passing through the equipment walls, floors or ceilings shall be protected against sound leakage by means of an acoustical seal, as described in Specification Q.

U. All vertical risers shall be supported by spring isolators designed to support the riser filled with water, if it is a water line. Assigned loads must be within the building design limits at the support points. Neutral central resilient anchors close to the center of the run shall direct movement up and down. The anchors shall be capable of holding an upward force equal to the water weight when the system is drained. If one level cannot accommodate this force, anchors can be located on 2 or 3 adjacent floors. Resilient guides shall be spaced and sized properly depending on the pipe diameter. Submittals must include the initial load, initial deflection, change in deflection, final load and change in load at all spring and anchor support locations, as well as guide spacing. The initial spring deflection shall be a minimum of 3/4" (19mm) or four times the thermal movement at the isolator location, whichever is greater. Calculations shall include pipe stress at end conditions and branch off locations and the manufacturer must include installation instructions. Submittal must be stamped and signed by a licensed professional engineer in the employ of the vibration vendor for at least 5 years. Proper provision shall be made for seismic protection in seismic zones. The isolator manufacturer shall be the same firm supplying the mechanical contract. Support spring mountings shall be Specification B, anchors Specification R, telescoping guides Specification S.

OPTIONAL ADDITION TO SPECIFICATION

The isolation vendor shall design and provide all brackets or clamps at riser spring guide and anchor locations. The contractor must install and adjust all isolators under the supervision of the isolator vendor or his representative.

V. All air ducts with a cross section of 2ft² (0.19m²) or larger shall be isolated from the building structure by Specification H hangers or B floor supports with a minimum deflection of 3/4" (19mm). Isolators shall continue for 50 ft (15m) from the equipment. If air velocity exceeds 1000 fpm (5.3mps), hangers or supports shall continue for an additional 50 ft (15m) or as shown on the drawings.

PART 3 - EXECUTION

3.01 General

- A. All vibration isolators must be installed in strict accordance with the manufacturers written instructions and all certified submittal data.
- B. Installation of vibration isolators must not cause any change of position of equipment, piping or duct work resulting in stresses or misalignment.
- C. No rigid connections between equipment and the building structure shall be made that degrades the noise and vibration control system herein specified.
- D. The contractor shall not install any equipment, piping, duct or conduit which makes rigid connections with the building unless isolation is not specified. "Building" includes, but is not limited to, slabs, beams, columns, studs and walls.
- E. Coordinate work with other trades to avoid rigid contact with the building.
- F. Any conflicts with other trades which will result in rigid contact with equipment or piping due to inadequate space or other unforeseen conditions should be brought to the architects/engineers attention prior to installation. Corrective work necessitated by conflicts after installation shall be at the responsible contractors expense.
- G. Bring to the architects/engineers attention any discrepancies between the specifications and the field conditions or changes required due to specific equipment selection, prior to installation. Corrective work necessitated by discrepancies after installation shall be at the responsible contractors expense.
- H. Correct, at no additional cost, all installations which are deemed defective in workmanship and materials at the contractors expense.
- I. Hand built elastomeric expansion joints may be used when pipe sizes exceed 24" (600mm) or specified movements exceed 2.02-O capabilities.
- J. Where piping passes through walls, floors or ceilings the vibration isolation manufacturer shall provide 2.02-Q seals.
- K. Locate isolation hangers as near to the overhead support structure as possible.
- L. Air handling equipment and centrifugal fans shall be protected against excessive displacement which results from high air thrust when thrust forces exceed 10% of the equipment weight. Horizontal thrust restraints shall be 2.02-I restraints.
- M. Rooftop equipment isolators must be bolted to the equipment and structure. Mountings must be designed to resist 100m/h (160 km/h) wind loads.

3.02 Vibration Isolation of Piping

- A. Horizontal pipe shall be installed in accordance with 2.02-T Horizontal Pipe Isolation.
- B. Risers shall be installed in accordance with 2.02-U Riser Isolation.

3.03 Vibration Isolation of Ductwork

- A. All duct runs shall be installed in accordance with 2.02-V Duct Isolation.

PART 4 - SCHEDULES

4.01 Equipment Isolator Schedule

The complete specification and specification product details are available electronically on the Mason web site or can be requested at "info@mason-ind.com".

EQUIPMENT SCHEDULE					VIBRATION ISOLATION		
Equipment Deflection No.	Location	Type	Motor (HP)	Motor (kw)	Isolator, Base, Restraint, Flexible Connector Specification Number	Static Deflection (in)	Static Deflection (mm)



Specification Product Details

SPECIFICATION A

ND DOUBLE DEFLECTION
NEOPRENE MOUNT

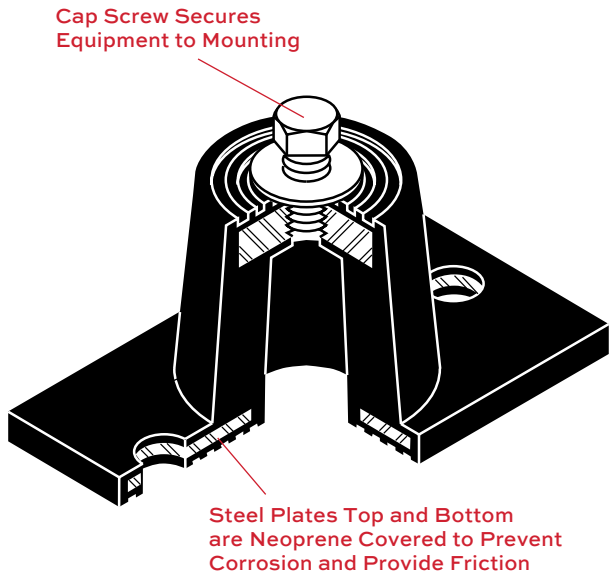

SPECIFICATION B

SLF SPRING MOUNT

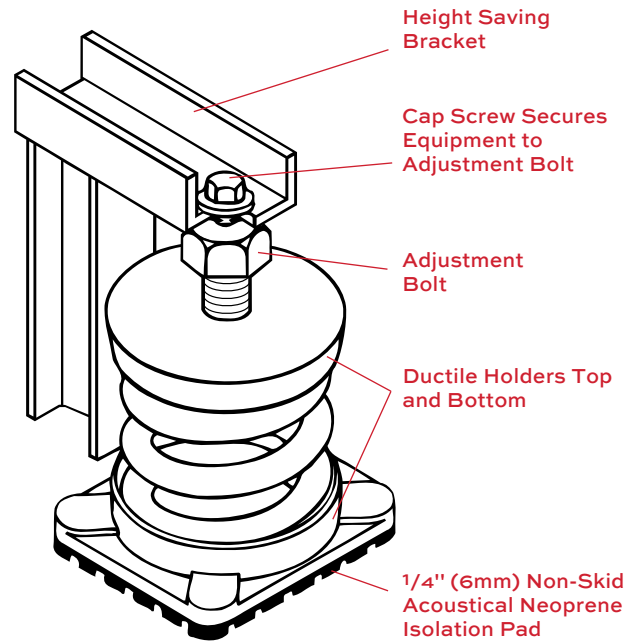

SPECIFICATION C

MT AIR SPRING MOUNT

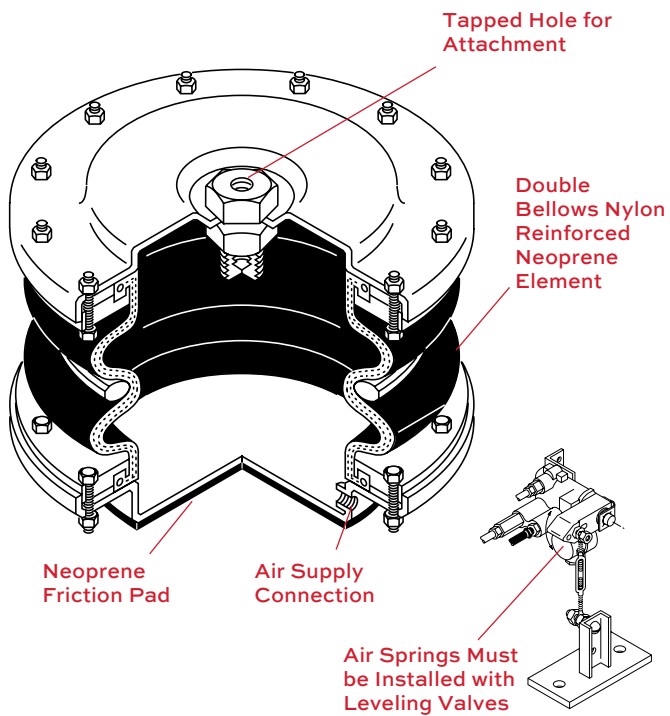

SPECIFICATION D

SLR & SLRSO SPRING MOUNTS

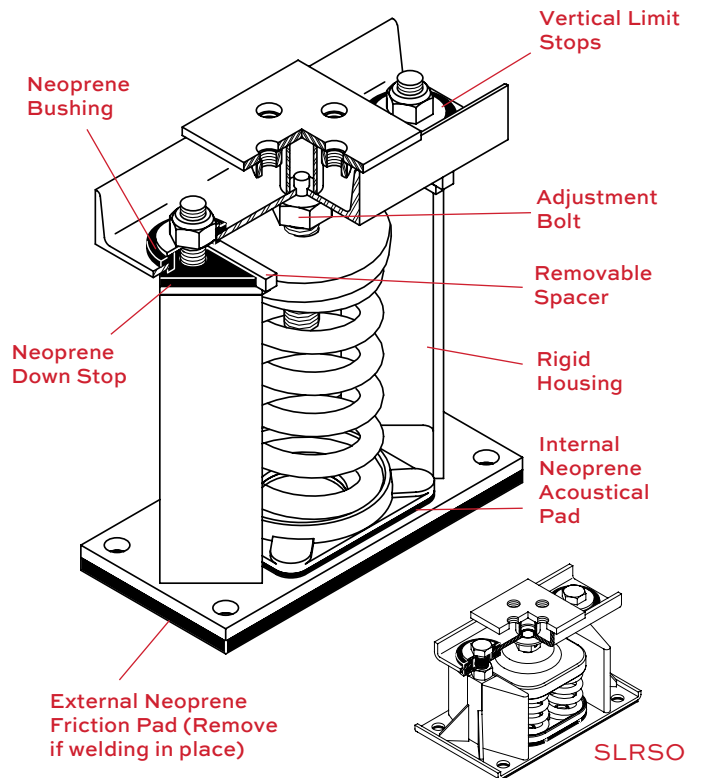

SPECIFICATION E

SLR-MT AIR SPRING MOUNT

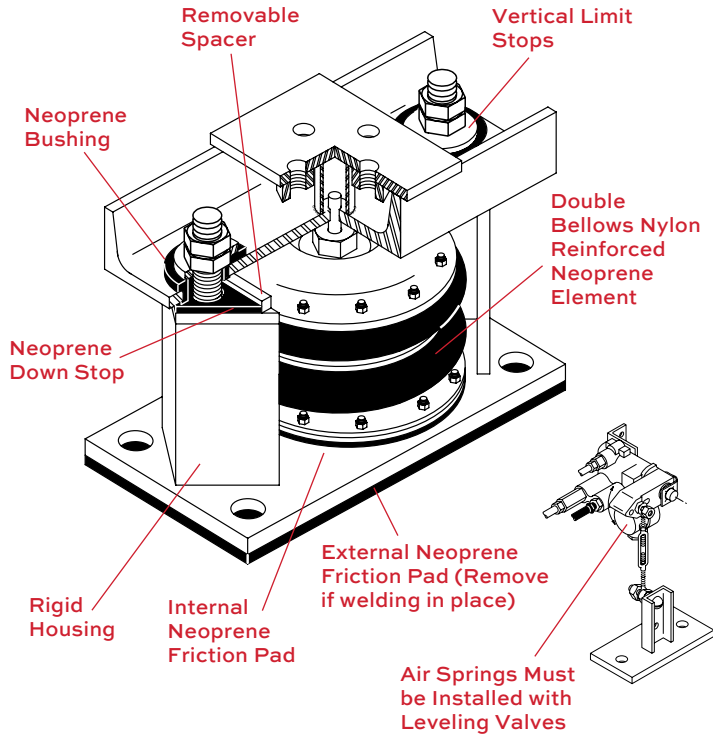

SPECIFICATION F

30N SPRING AND LDS RUBBER HANGER

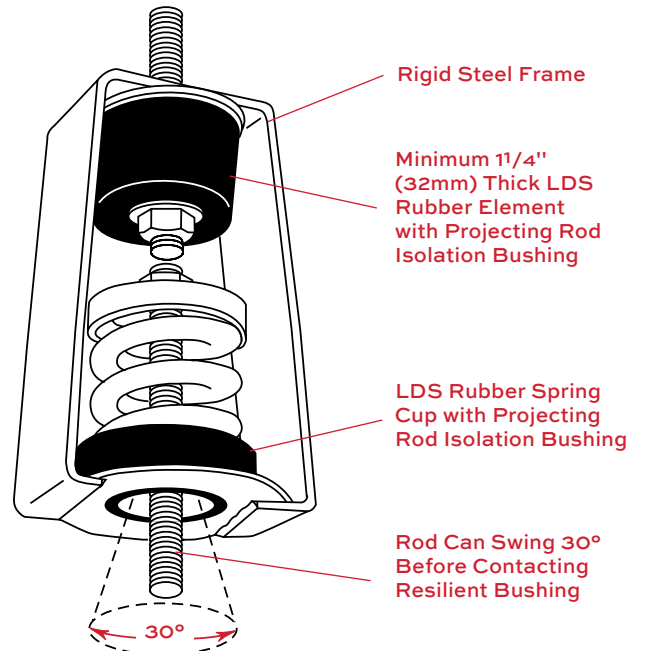

SPECIFICATION G

PC30N PRECOMPRESSED SPRING AND LDS RUBBER HANGER

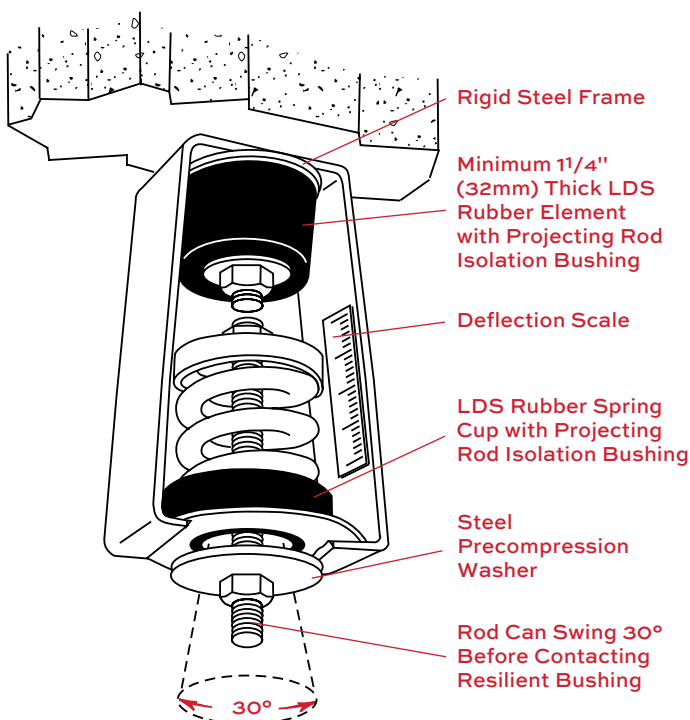

SPECIFICATION H

W30 PRECOMPRESSED SPRING AND LDS RUBBER HANGER

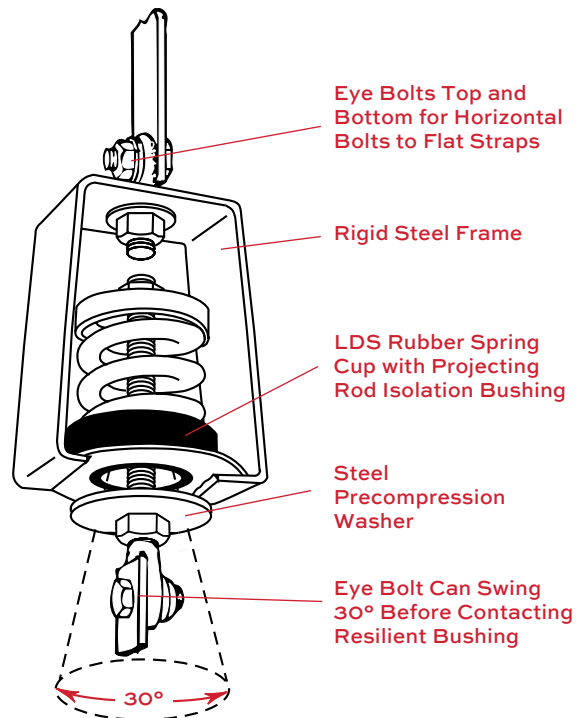

SPECIFICATION I

**WB HORIZONTAL THRUST RESTRAINTS
USED IN PAIRS**

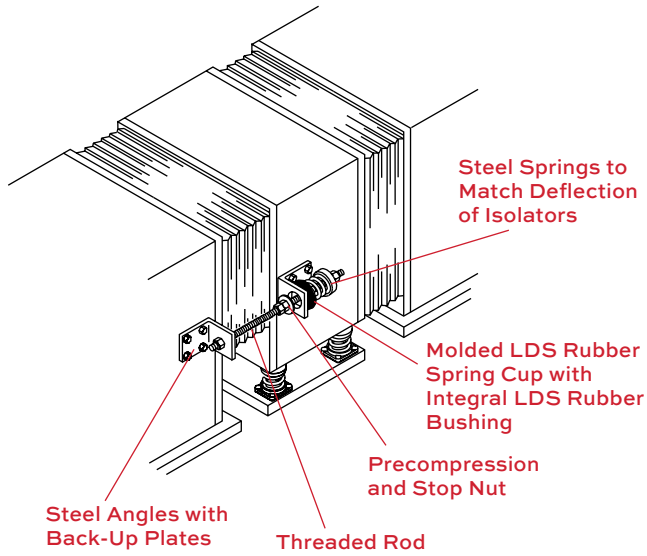

SPECIFICATION J

WF STEEL BEAM BASE

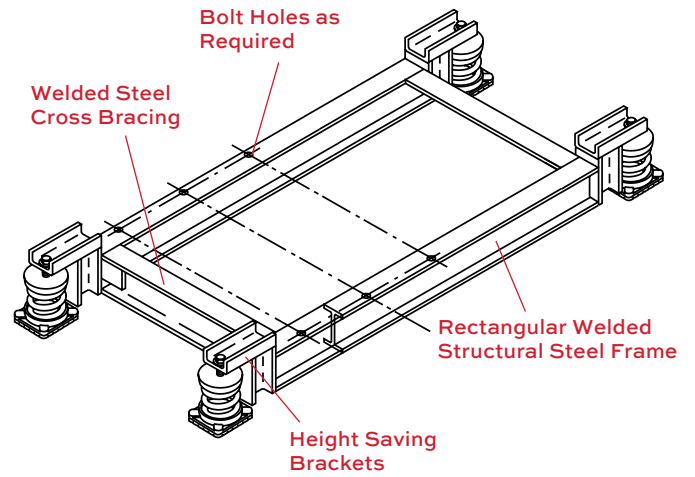

SPECIFICATION K

ICS STEEL BEAM RAILS

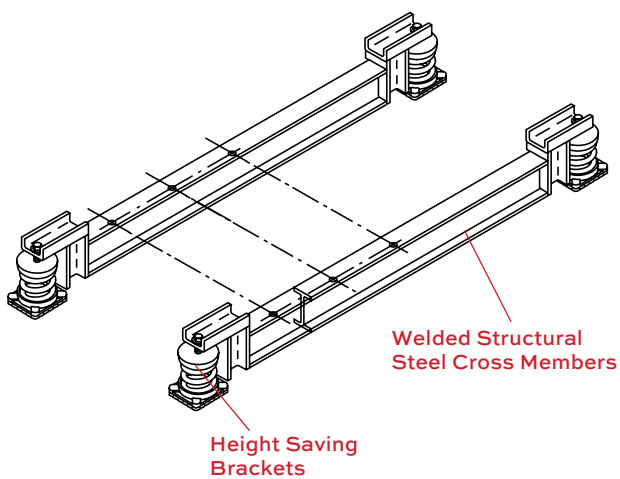

SPECIFICATION L

BMK CONCRETE FORM BASE

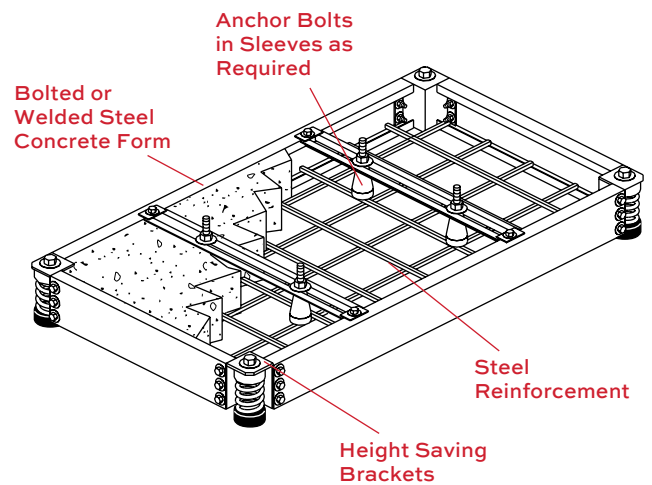

SPECIFICATION M

CMAB CURB MOUNTED ALUMINUM BASE

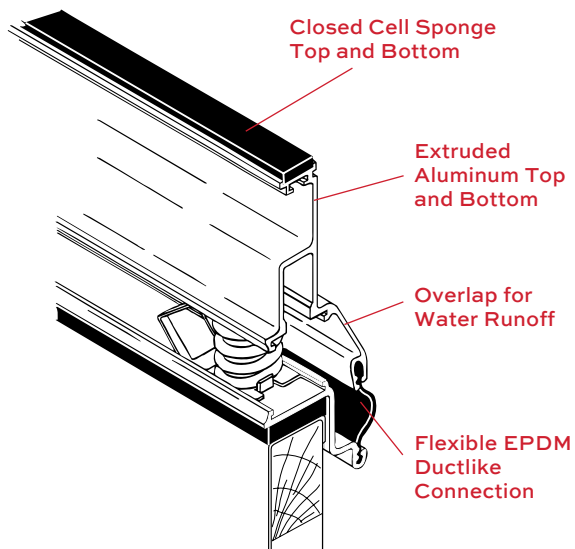

SPECIFICATION N

RSC ROOF TOP CURB

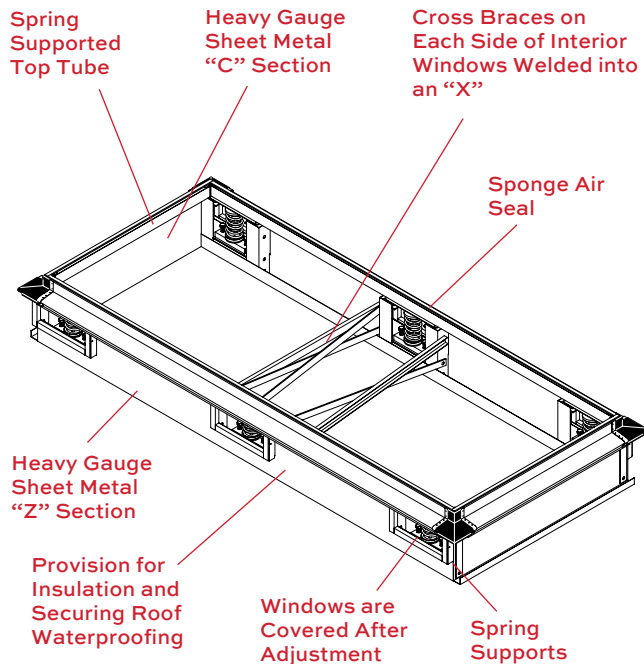

SPECIFICATION O

SFDEJ MOLDED RUBBER EXPANSION JOINT

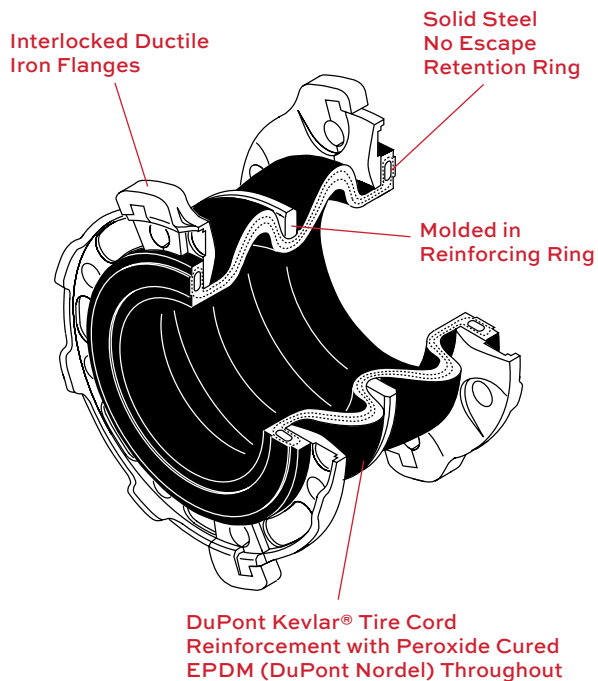

SPECIFICATION P

BSS STAINLESS STEEL AND CPSB BRONZE HOSE

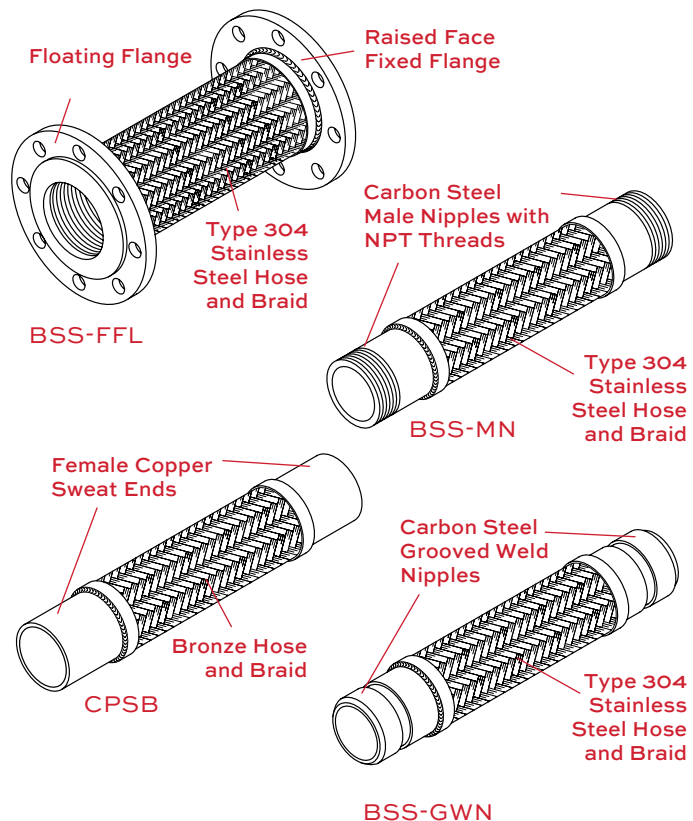

SPECIFICATION Q

SWS ACOUSTICAL WALL, CEILING OR FLOOR SEAL

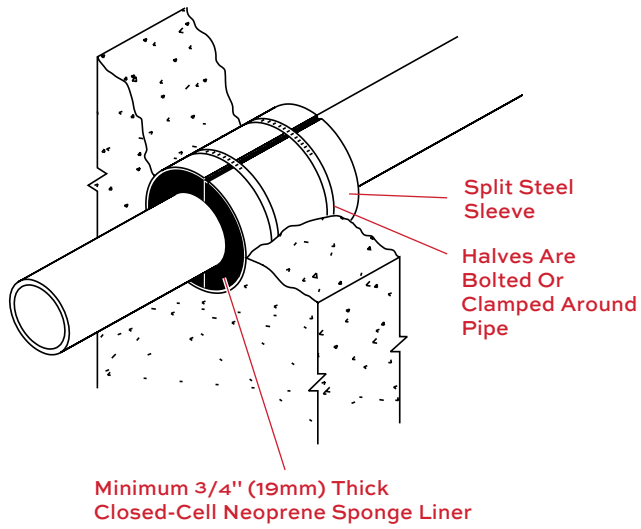

SPECIFICATION R

ADA ALL DIRECTIONAL ANCHOR

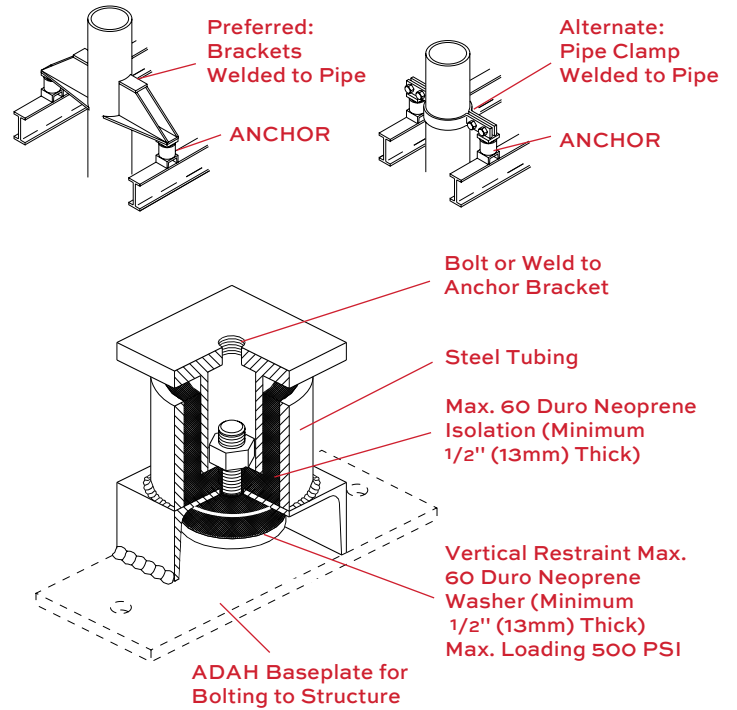

SPECIFICATION S

VSG VERTICAL SLIDING GUIDES

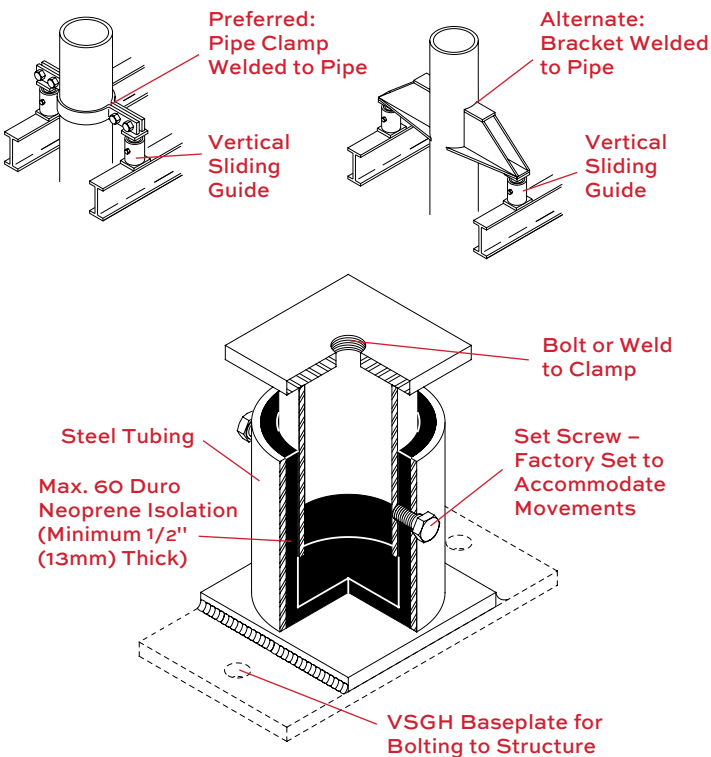

These specifications are also available electronically as live text and AutoCAD files on our web site at: <https://www.mason-ind.com/service/hvac-engineering/> or scan the QR code below.

